



**MANUFACTURED BY:**  
**Backyard Discovery**  
3305 Airport Drive, Pittsburg, KS 66762  
800-856-4445

Basepoint Business Centre: Rivermead Drive, Westlea, Swindon SN5 7EX Phone: 0800-118-2476  
J.P. Coenstraat 7, The Bridge, The Hague, 2595 WP, Netherlands Phone: 0800-567-8990

# ENDEAVOR II

## Swing Set

### Model # 2200135 & 2300064



**WARNING**  
**Adult Assembly Required.**  
Not suitable for children under 36 months due to small parts.  
**FOR DOMESTIC USE ONLY. INTENDED FOR OUTDOOR USE.**



**Please visit [www.backyarddiscovery.com](http://www.backyarddiscovery.com)**

For the most up to date assembly manual, to register your set, or to order replacement parts  
*Para obtener instrucciones en español, visite [www.backyarddiscovery.com](http://www.backyarddiscovery.com)*



**EASY STEP-BY-STEP**  
**3D INTERACTIVE INSTRUCTIONS**

DOWNLOAD THE FREE APP



**INSTALLATION**  
**SERVICES**  
**AVAILABLE!**  
*See inside for details*

Made in China  
INS-2200135-A-ENDEAVOR II-ENG 8-10-22  
INS-2300064-A-ENDEAVOR II-ENG 8-10-22

# Owner's Manual - Basic Setup Dimensions & Assembly Notes

Place the set on level ground, not less than 6'-7" [2 m] from any structure or obstruction such as a fence, garage, house, overhanging branches, laundry lines, or electrical wires.

- While assembling unit, take time before and after each phase to make sure fort is level. If fort is not level, assembly will be difficult and improper assembly may result. Extra care must be taken to insure the fort is square.
- The safe play area refers to a zone extending 6'-7" (2 m) beyond the play product on all sides, including the space above the play product.

## SAFE PLAY AREA DIAGRAM

### Ground Dimensions

22'-5 3/4" [6.8 m] x 10'-1 1/4" [3.1 m] x 9'-10 3/4" [3 m]

### Safe Play Area

35'-7 1/2" [10.9 m] x 23'-3 1/4" [7.1 m] x 16'-5 3/4" [5 m]

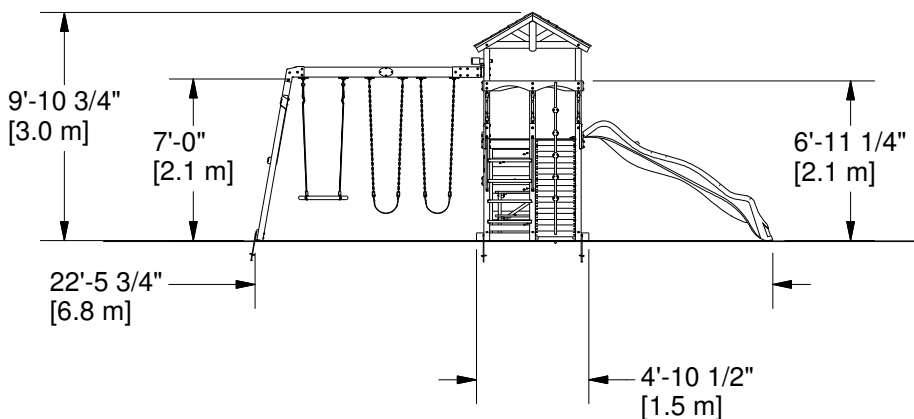
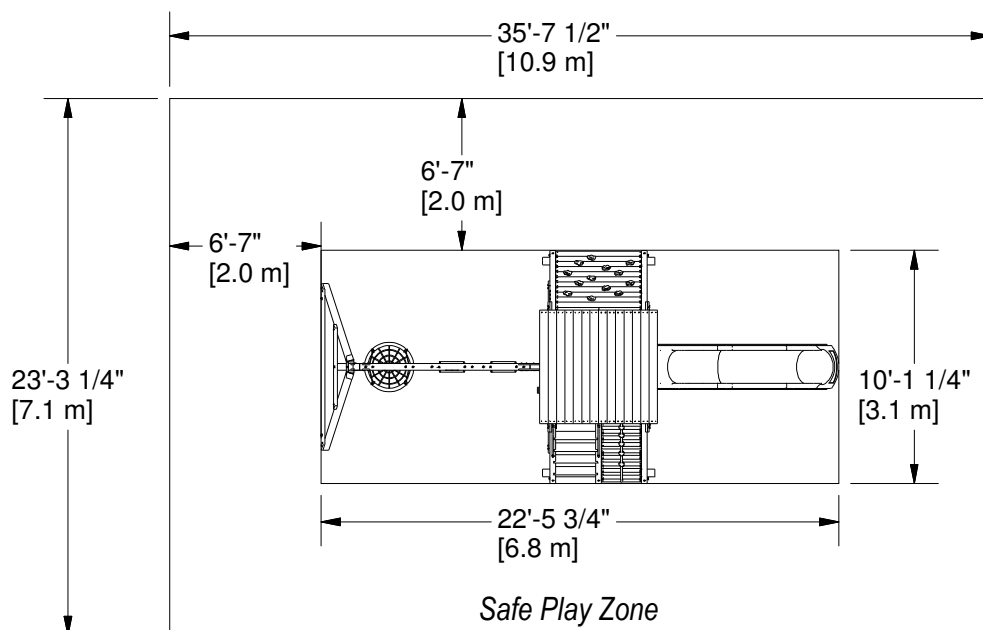

SAFE PLAY HEIGHT: 16'-5 3/4" [5 m]  
 MAXIMUM FALL HEIGHT: 7' [2.1 m]

### General Information:

Your set has been designed and engineered for children only and for residential use only.  
 A maximum of 150 lbs. per child is recommended for play activities designed for individual use.  
 A maximum of 120 lbs. per child is recommended for play activities designed for multiple child use.  
 A maximum of 9 children is recommended for this swing set.

# Owner's Manual - Parts Identification

## Wood Components (Not to Scale)



**A50** | SWING BEAM 3 POSITION - W4L16461  
(x1) | 3 3/8"x5 1/4"x89 1/2" (86x134x2274)



**A2** | SB 9" BLOCK - W4L16459  
(x1) | 3 3/8"x5 1/4"x9" (86x134x228)



**AL01** | STEP - W4L16431  
(x4) | 1 3/8"x4 3/8"x22 3/4" (36x112x579)

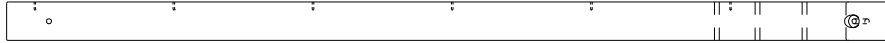

**B02** | LEG - W4L16417  
(x1) | 3"x3"x69 1/4" (76x76x1760)

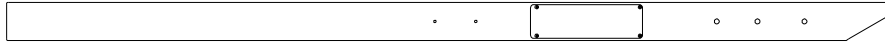

**B03** | LEG - W2A03278  
(x1) | 3"x3"x69 1/4" (76x76x1760)



**B04** | UPRIGHT - W4L16419  
(x1) | 3"x3"x35" (76x76x888)

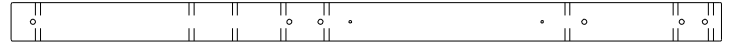

**B06** | UPRIGHT - W4L16425  
(x2) | 3"x3"x55 1/2" (76x76x1410)

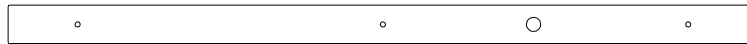

**B07** | GROUND BOARD - W4L16427  
(x1) | 3"x3"x58 5/8" (76x76x1488)



**B08** | LEG - W4L16433  
(x1) | 3"x3"x69 1/4" (76x76x1760)

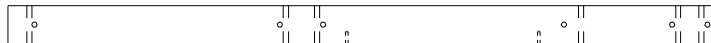

**B10** | UPRIGHT - W4L16435  
(x2) | 3"x3"x55 1/2" (76x76x1410)

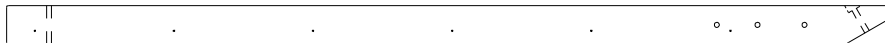

**B11** | LEG - W4L16441  
(x1) | 3"x3"x69 1/4" (76x76x1760)



**B12** | GROUND BOARD - W4L16446  
(x1) | 3"x3"x58 5/8" (76x76x1488)

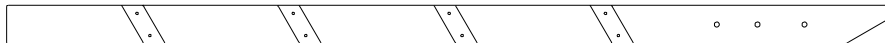

**B13** | LEG - W4L16476  
(x1) | 3"x3"x69 1/4" (76x76x1760)



**B50** | ANGLE BRACE - W4L16463  
(x2) | 3"x3"x87 1/8" (76x76x2212)

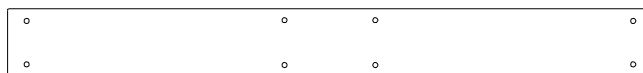

**D01** | WALL RAIL - W4L16426  
(x1) | 1 3/8"x5 1/4"x50 3/8" (36x134x1280)



**D02** | WALL RAIL - W4L16422  
(x1) | 1 3/8"x5 1/4"x50 3/4" (36x134x1288)

# Owner's Manual - Parts Identification

## Wood Components (Not to Scale)

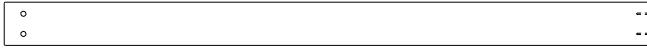

**E01 | FLOOR JOIST - W4L16420**  
(x1) | 1 3/8"x3 3/8"x50 3/8" (36x86x1280)



**E05 | BLOCK - W4L16474**  
(x1) | 1 3/8"x3 3/8"x4 3/4" (36x86x120)

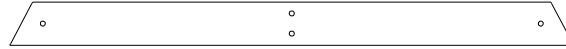

**E50 | END SUPPORT - W4L16464**  
(x1) | 1 3/8"x3 3/8"x44 1/8" (36x86x1120)



**F01 | CLEAT - W4L16440**  
(x4) | 1 3/8"x2"x59 1/2" (36x52x1510)



**F05 | UPPER SUPPORT - W4L16470**  
(x2) | 1 3/8"x2 3/8"x16 3/4" (36x60x424)



**F06 | LEG - W4L16471**  
(x4) | 1 3/8"x2 3/8"x29 7/8" (36x60x757)



**F08 | LEG SUPPORT - W4L16472**  
(x2) | 1 3/8"x2 3/8"x39 5/8" (36x60x1006)



**F12 | ANGLE BRACE - W4L16473**  
(x2) | 1 3/8"x2 3/8"x20" (36x60x507)



**G01 | ROCK WALL BOARD - W4L16452**  
(x2) | 1"x5 1/4"x44 5/8" (24x134x1135)



**G02 | WALL RAIL - W4L16423**  
(x1) | 1"x5 1/4"x50 3/8" (24x134x1280)



**G03 | WALL RAIL - W4L16424**  
(x1) | 1"x5 1/4"x50 3/4" (24x134x1288)



**G04 | WALL RAIL - W4L16443**  
(x1) | 1"x5 1/4"x50 3/8" (24x134x1280)



**G05 | ROCK WALL BOARD - W4L16444**  
(x5) | 1"x5 1/4"x44 5/8" (24x134x1135)



**G06 | ROCK WALL BOARD - W4L16445**  
(x4) | 1"x5 1/4"x44 5/8" (24x134x1135)



**G50 | GROUND BOARD - W4L16465**  
(x1) | 1"x5 1/4"x86 3/4" (24x134x2202)

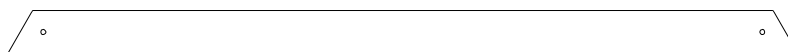

**H01 | FLOOR RAIL - W4L16428**  
(x1) | 1"x3 3/8"x61 3/4" (24x86x1569)



**H02 | FLOOR RAIL - W4L16429**  
(x2) | 1"x3 3/8"x18 3/4" (24x86x477)



**H03 | FLOOR RAIL - W4L16430**  
(x5) | 1"x3"x3 3/8" (24x76x86)

# Owner's Manual - Parts Identification

## Wood Components (Not to Scale)



**H04** | ROPE WALL BOARD - W4L16438  
(x8) | 1"x3 3/8"x20 7/8" (24x86x529)



**H05** | WALL RAIL - W4L16450  
(x2) | 1"x3 3/8"x29 7/8" (24x86x760)

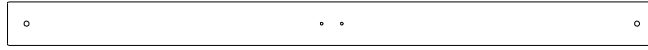

**H07** | WALL RAIL - W4L16453  
(x2) | 1"x3 3/8"x50 3/4" (24x86x1288)



**H08** | WALL RAIL - W4L16454  
(x2) | 1"x3 3/8"x52 1/4" (24x86x1328)



**H09** | ROOF RAIL - W4L16455  
(x4) | 1"x3 3/8"x34 1/2" (24x86x877)



**H10** | GABLE BOARD - W4L16456  
(x2) | 1"x3 3/8"x15 3/4" (24x86x400)



**H11** | GABLE CLEAT - W4L16457  
(x2) | 1"x3"x3 3/8" (24x76x86)



**H12** | GABLE BOARD - W4L16458  
(x4) | 1"x3 3/8"x14 5/8" (24x86x370)

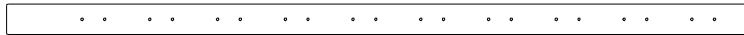

**J01** | ROCK WALL CLEAT - W4L16447  
(x1) | 1"x2 3/8"x58 1/2" (24x60x1486)



**K04** | FLOOR BOARD - W4L16448  
(x1) | 5/8"x4 3/4"x44 5/8" (16x120x1135)



**K05** | FLOOR BOARD - W4L16449  
(x1) | 5/8"x4 3/4"x20 7/8" (16x120x529)

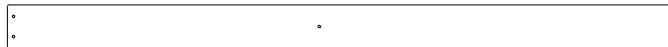

**M01** | FLOOR BOARD - W4L16437  
(x13) | 5/8"x3 3/8"x52 3/4" (16x86x1339)



**M02** | ROPE WALL BOARD - W4L16436  
(x8) | 5/8"x3 3/8"x20 7/8" (16x86x529)

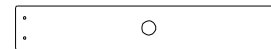

**M03** | ROPE WALL BOARD - W4L16451  
(x1) | 5/8"x3 3/8"x20 7/8" (16x86x529)



**M04** | PICKET - W4L16466  
(x9) | 5/8"x3 3/8"x29 7/8" (16x86x760)



**M05** | SAFETY BOARD - W4L16467  
(x1) | 5/8"x3 3/8"x26 7/8" (16x86x682)

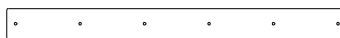

**N01** | ROOF CLEAT - W4L16460  
(x4) | 5/8"x2 3/8"x26 5/8" (16x60x675)

# Owner's Manual - Parts Identification

## Wood Components (Not to Scale)



**O70** | SLIDE MOUNTING BOARD - W4L09040  
(x1) | 5/8"x1 3/8"x20 3/8" (16x34x517)



**Q01** | FLOOR RAIL - W4L16173  
(x2) | 1"x4 3/8"x67 5/8" (24x112x1718)



**Q02** | FLOOR RAIL - W4L16418  
(x1) | 1"x4 3/8"x50 3/4" (24x112x1288)

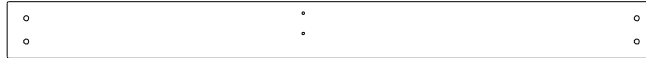

**Q03** | FLOOR RAIL - W4L16421  
(x1) | 1"x4 3/8"x50 3/4" (24x112x1288)



**Q04** | SAFETY RAIL - W4L16475  
(x1) | 1"x4 3/8"x89 1/2" (24x112x2274)



**SP01** | SWING BEAM SUPPORT - W4L16462  
(x1) | 3 3/8"x3 3/8"x50" (86x86x1269)

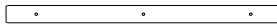

**T01** | CLEAT - W4L16442  
(x3) | 1"x1 3/8"x21 1/2" (24x34x546)



**Y01** | FLOOR BOARD - W4L16432  
(x2) | 5/8"x4"x20 7/8" (16x102x529)



**Y02** | FLOOR BOARD - W4L16439  
(x1) | 5/8"x4"x44 5/8" (16x102x1135)

# Owner's Manual - Parts Identification

## Wood Components (Not to Scale)



**RP1** | ROOF PANEL - W2A03410  
(x2) | 1 5/8"x15"x59 1/8" (42x382x1503)



**RP2** | ROOF PANEL - W2A03411  
(x2) | 1 5/8"x20 5/8"x66" (42x524x1503)



**TP1** | PICNIC TABLE TOP - W2A03413  
(x1) | 1 7/8"x16 15/16"x40 11/16" (48x430x1034)

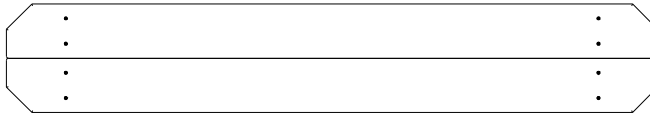

**TP2** | PICNIC TABLE SEAT - W2A03414  
(x2) | 1 9/16"x6 3/4"x40 11/16" (40x172x1034)

# Owner's Manual - Parts Identification

## Hardware Components

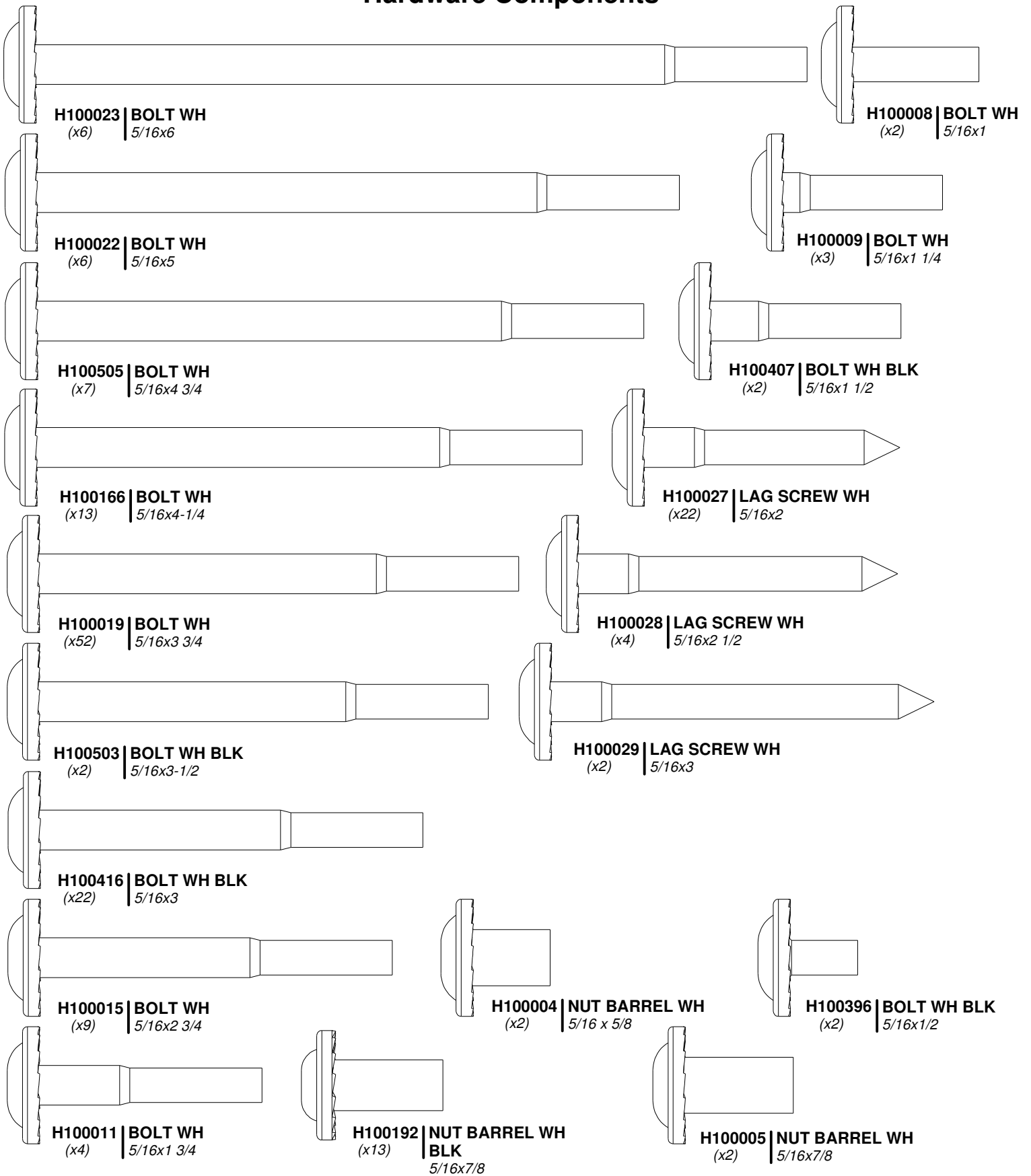



# Owner's Manual - Parts Identification

## Hardware Components

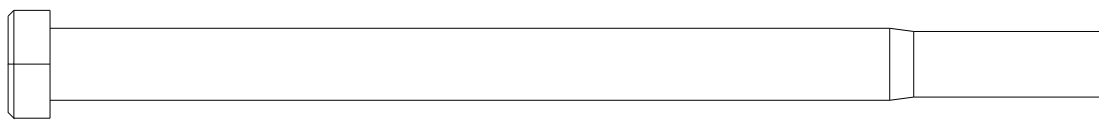

**H100654 | BOLT HEX**  
(x13) | 3/8x5-1/2

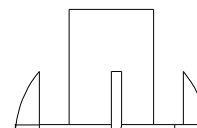

**H100073 | T-NUT**  
(x13) | 3/8

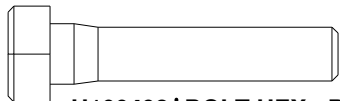

**H100498 | BOLT HEX - BLK**  
(x4) | 5/16x1 1/2

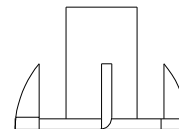

**H100074 | T-NUT**  
(x103) | 5/16

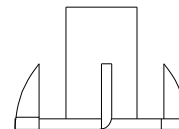

**H100379 | T-NUT BLK**  
(x9) | 5/16

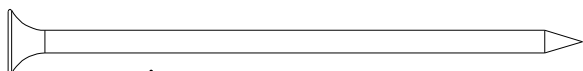

**H100092 | SCREW PFH**  
(x46) | 8x3

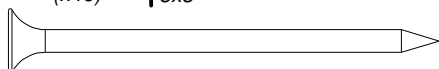

**H100091 | SCREW PFH**  
(x41) | 8X2 1/4

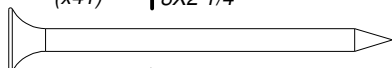

**H100111 | SCREW PFH**  
(x80) | 8x2

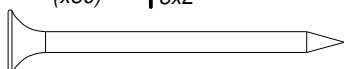

**H100089 | SCREW PFH**  
(x77) | 8x1 3/4

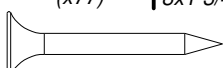

**H100088 | SCREW PFH**  
(x4) | 8x1 1/8

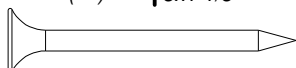

**H100086 | SCREW PFH**  
(x191) | 8x1 1/2

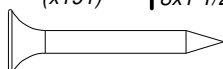

**H100380 | SCREW PFH BLK**  
(x26) | 8x1 1/8

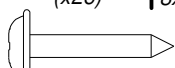

**H100070 | SCREW PWH**  
(x4) | 8x3/4

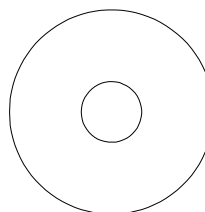

**H100478 | WASHER FLAT**  
(x4) | BLK  
8x27

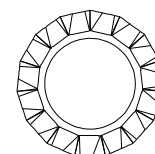

**H100031 | WASHER LOCK**  
(x4) | EXT  
12x19

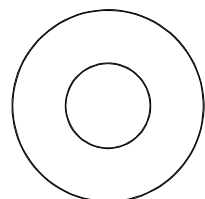

**H100102 | WASHER FLAT**  
(x13) | 11x25

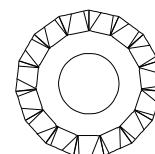

**H100030 | WASHER LOCK**  
(x102) | EXT  
8x19

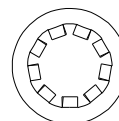

**H100108 | WASHER LOCK**  
(x28) | INT  
8x15

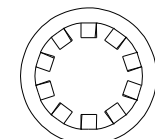

**H100107 | WASHER LOCK**  
(x13) | INT  
10x18

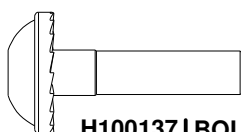

**H100137 | BOLT WH**  
(x28) | 1/4x1

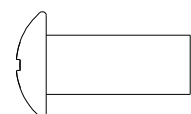

**H100831 | NUT BARREL PTH**  
(x4) | BLK  
1/4x3/4

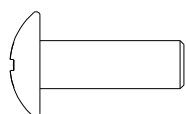

**H100832 | BOLT PTH BLK**  
(x4) | (with LOCTITE)  
1/4x3/4

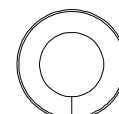

**H100477 | WASHER SPLIT**  
(x4) | BLK  
5/16

# Owner's Manual - Parts Identification

## Accessory Components (Not to Scale)



**A100164** | **BYD ID TAG**  
(x1) | **(LARGE) AGES**  
3-10

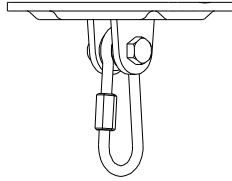

**A4M00505** | **SWING HANGER**  
(x6)

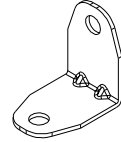

**A4M01047** | **L BRACKET**  
(x2) | **2.5x38x55x55**

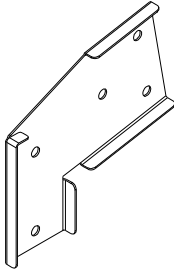

**A4M00617** | **SWING BEAM**  
(x1) | **EXTENSION**  
**BRACKET-LEFT**

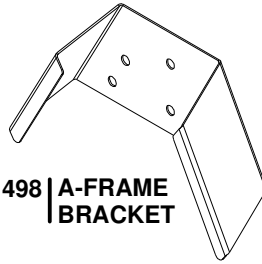

**A4M01498** | **A-FRAME**  
(x1) | **BRACKET**

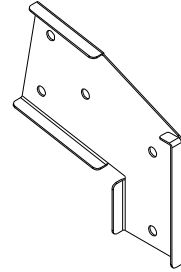

**A4M00618** | **SWING BEAM**  
(x1) | **EXTENSION**  
**BRACKET-RIGHT**

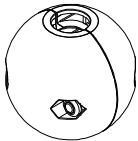

**A6P00508** | **ROPE CLAMP KIT**  
(x7)

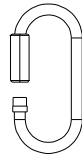

**A100069** | **QUICK LINK**  
(x4)

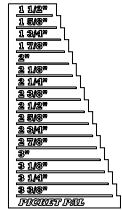

**A6P00410** | **PICKET PAL**  
(x1)



**A100047** | **CHAIN GREEN**  
(x4) | **57"**

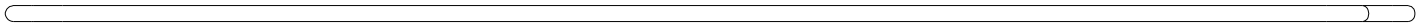

**A6P00520** | **ROPE**  
(x1)



**A100027** | **SWING SEAT**  
(x2) | **GREEN 26"**

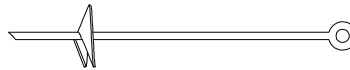

**A100178** | **AUGER GROUND**  
(x6) | **STAKE**

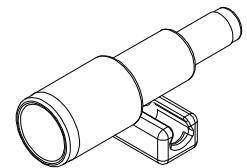

**A6P00096** | **TELESCOPE**  
(x1)

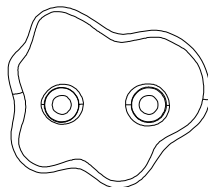

**A6P00036** | **GREEN HC ROCK**  
(x7) | **#1**

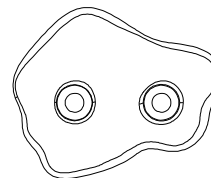

**A6P00037** | **GREEN HC ROCK**  
(x6) | **#2**

# Owner's Manual - Parts Identification

## Accessory Components (Not to Scale)

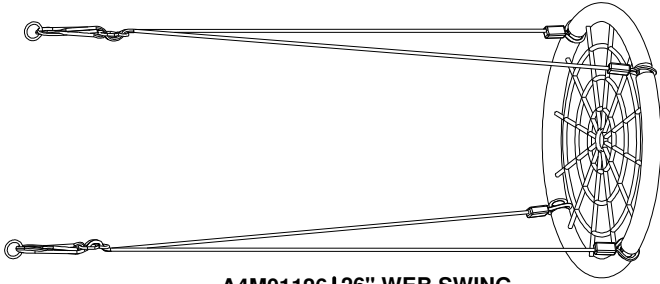

**A4M01126** | 26" WEB SWING SEAT ROPE  
(x1)

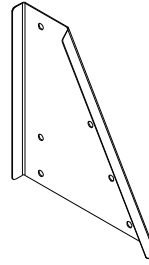

**A4M01481** | A-FRAME BRACKET-RT  
(x2)

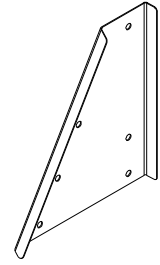

**A4M01482** | A-FRAME BRACKET-LT  
(x2)

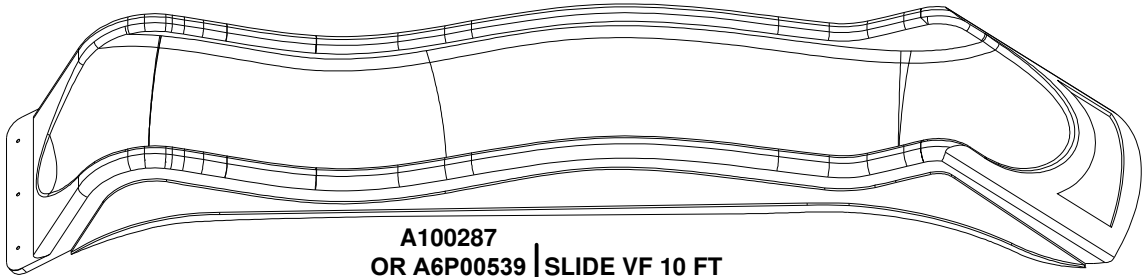

**A100287**  
OR **A6P00539** | SLIDE VF 10 FT  
(x1)

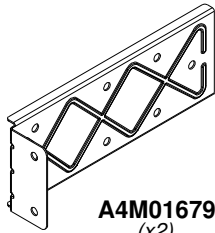

**A4M01679** | EXTENDED SWING BEAM BRACKET  
(x2)

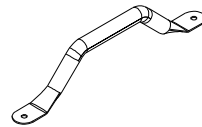

**A100118** | HAND GRIP METAL GREEN 381 c/c  
(x5)

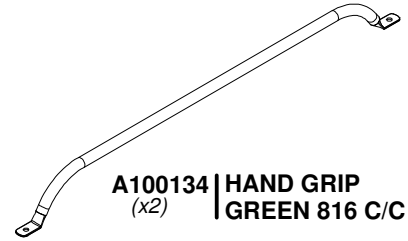

**A100134** | HAND GRIP GREEN 816 C/C  
(x2)

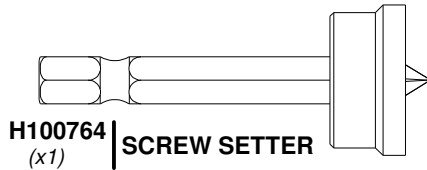

**H100764** | SCREW SETTER  
(x1)

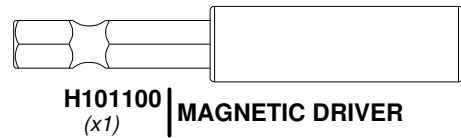

**H101100** | MAGNETIC DRIVER  
(x1)

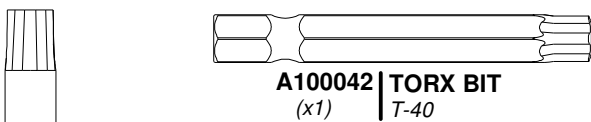

**A100042** | TORX BIT T-40  
(x1)

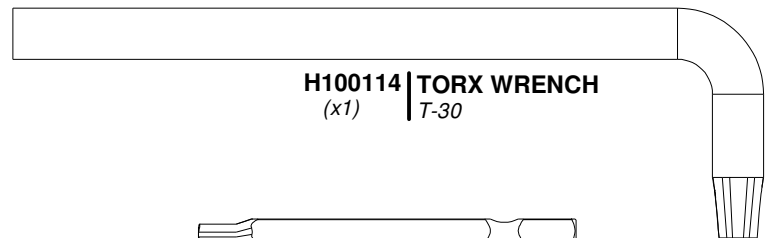

**H100114** | TORX WRENCH T-30  
(x1)

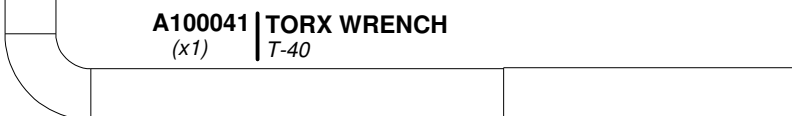

**A100041** | TORX WRENCH T-40  
(x1)

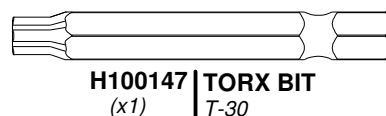

**H100147** | TORX BIT T-30  
(x1)

# PRE-ASSEMBLY STEP 1 - SORTING PARTS

It is critical for ease of assembly that you take the time to sort and organize the wood and hardware.

---

## WOOD PARTS:

- Organize wood parts by the three-digit, alpha-numeric number stamped on each board (ex. P01).
- If there are multiple boards with the same stamped number, stack those pieces together.
- Stamps can be found on the flat surface of the boards or on the end of the boards.
- Allow yourself plenty of room - the wood pieces can take up a significant amount of space.

**NOTE: CARTONS ARE NOT ORGANIZED BY BOARD NUMBER.**

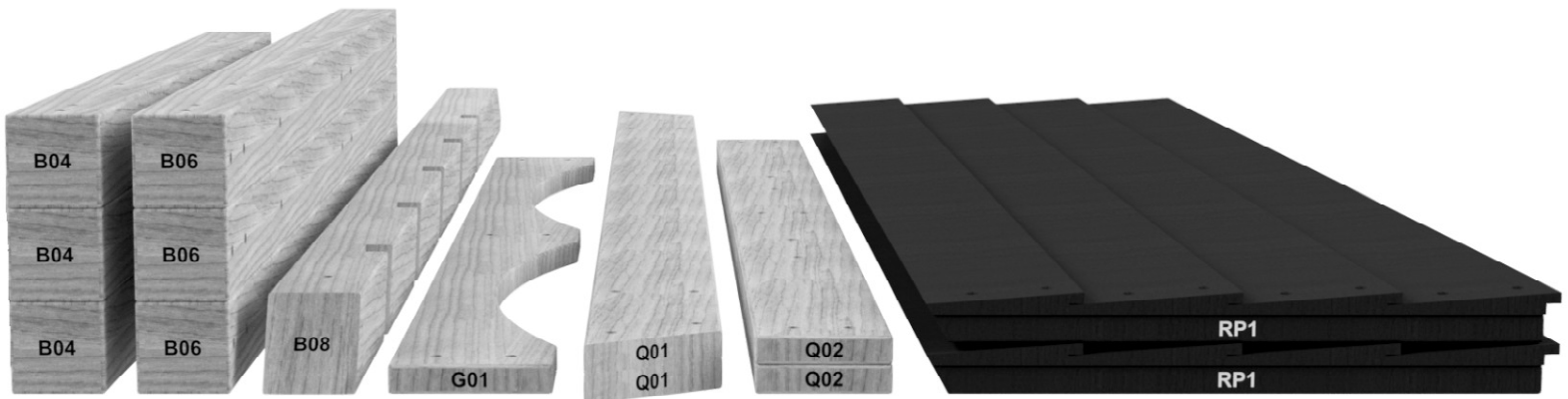

---

## HARDWARE PARTS:

- We recommend that you have a separate table to organize the hardware.
- Hardware bags are printed with a seven-digit, alpha-numeric part number.
- You can organize your hardware by part number or group by hardware type (i.e. bolts, nuts, etc.).
- During assembly you only need to reference the last four digits of the number.

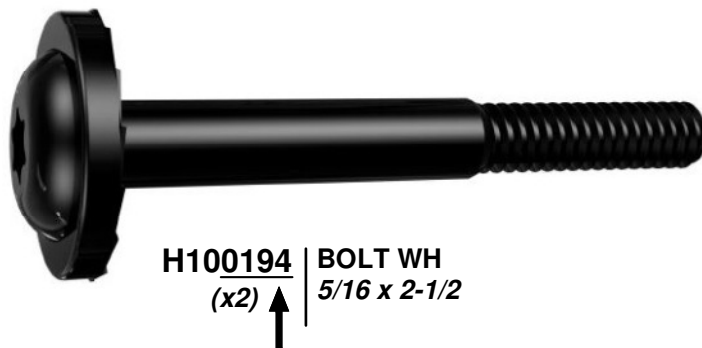

# PRE-ASSEMBLY STEP 2 - TOOLS REQUIRED



Cordless Drill or  
Electric Drill



Drill Attachments:  
Phillips Head



1/8", 3/16", 3/8" & 7/16"  
Drill Bits



Phillips Screw Driver



Open End Wrenches 1/2" & 9/16"



3/8" Drive Ratchet, 1/2" &  
9/16" STD Sockets 1/2" & 9/16"  
Deep Sockets



Claw Hammer



Rubber Mallet - Optional

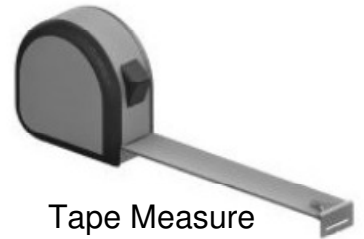

Tape Measure

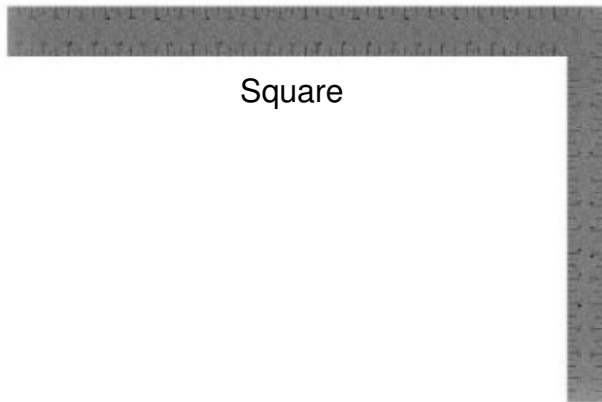

Square





Level 24"

# PRE-ASSEMBLY STEP 3 - CHOOSE YOUR ASSEMBLY METHOD



There are several types of assembly instructions available to you.

1. Printed Assembly Manual included with your set
2. BILT APP - 3D interactive instructions
3. Combination of the Printed Manual and BILT APP (Note: Step numbers can differ between the two methods)

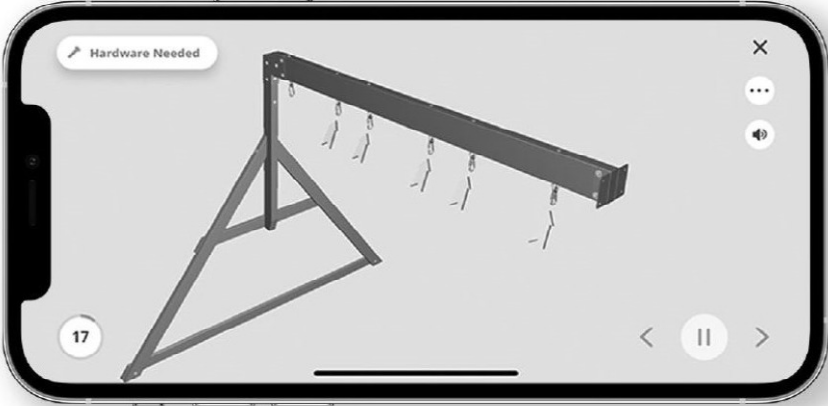

## Scan for easy 3D instructions

Download the BILT app  
before you begin



The image shows a smartphone screen displaying the BILT app interface. The screen features a 3D assembly diagram of a metal frame with a horizontal beam and several hanging components. The interface includes a 'Hardware Needed' button at the top left, a close button (X) at the top right, a menu button (three dots) and a volume icon below it, and a page number '17' in a circle at the bottom left. At the bottom center, there are navigation arrows and a pause button.

# STEP 1 - PICNIC TABLE

QTY	PART NUMBER	DESCRIPTION
8	H100015	BOLT WH 5/16x2 3/4
8	H100030	WASHER LOCK EXT 8x19
8	H100074	T-NUT 5/16

**F05** | UPPER SUPPORT - W4L16470  
 (x2) | 1 3/8"x2 3/8"x16 3/4" (36x60x424)

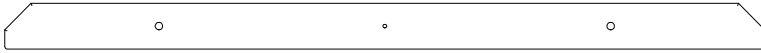

**F08** | LEG SUPPORT - W4L16472  
 (x2) | 1 3/8"x2 3/8"x39 5/8" (36x60x1006)

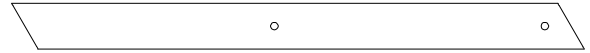

**F06** | LEG - W4L16471  
 (x4) | 1 3/8"x2 3/8"x29 7/8" (36x60x757)

**TIP:**  
**INSTALL T-NUTS IN WOOD FIRST**

**BUILD (2) LEG ASSEMBLIES**

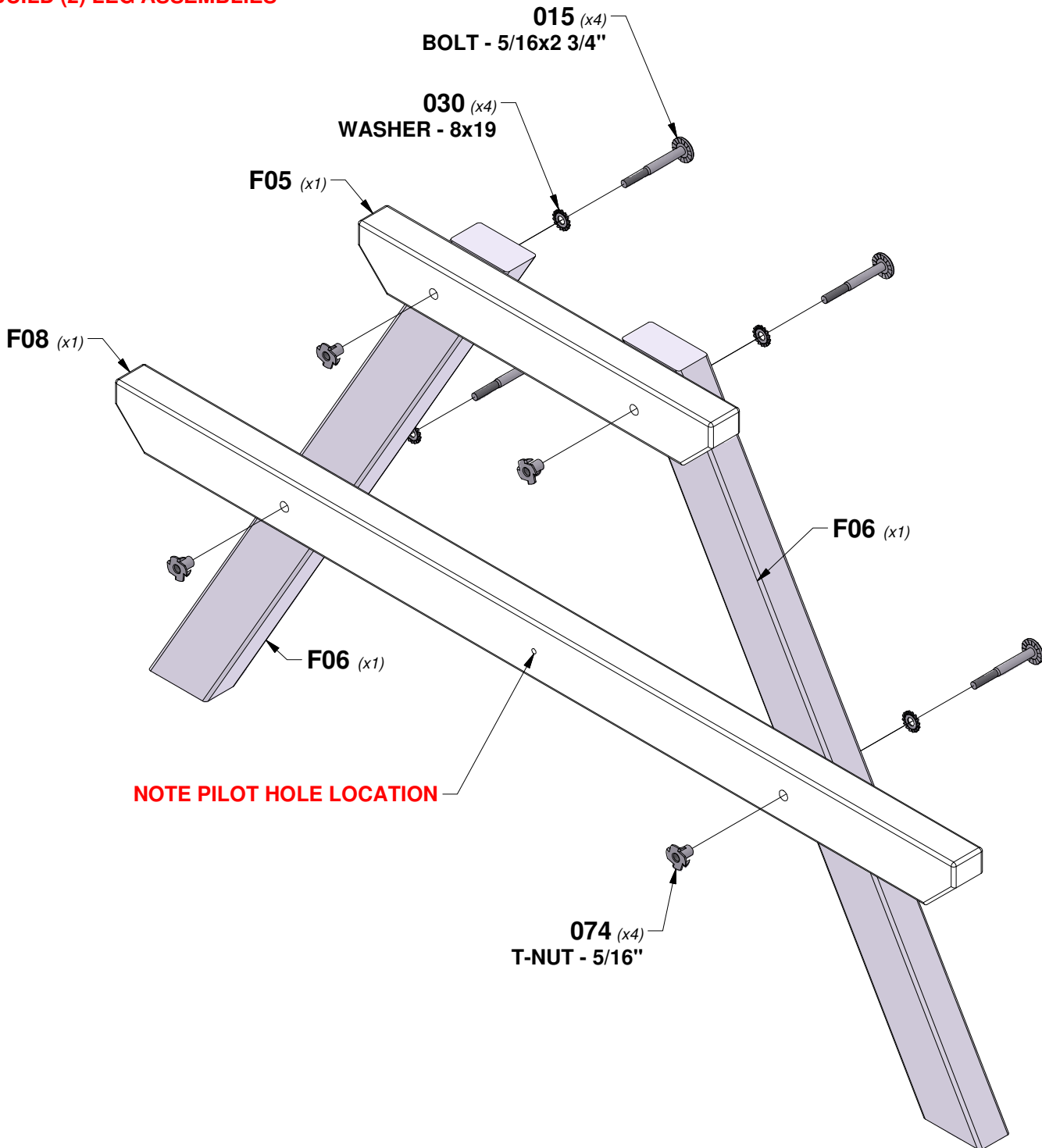

# STEP 2 - PICNIC TABLE

QTY	PART NUMBER	DESCRIPTION
4	H100089	SCREW PFH 8x1-3/4"
4	H100091	SCREW PFH 8x2 1/4"

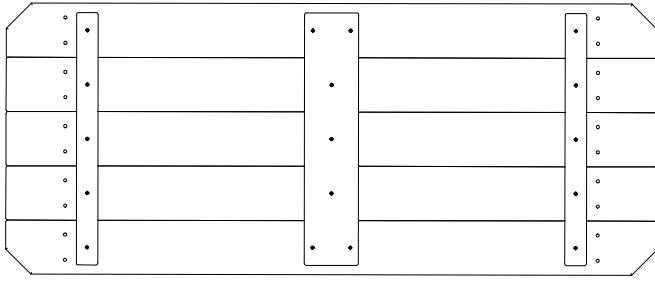

**TP1** | PICNIC TABLE TOP - W2A03413  
 (x1) | 1 7/8"x16 15/16"x40 11/16" (48x430x1034)



**F12** | ANGLE BRACE - W4L16473  
 (x2) | 1 3/8"x2 3/8"x20" (36x60x507)



**E05** | BLOCK - W4L16474  
 (x1) | 1 3/8"x3 3/8"x4 3/4" (36x86x120)

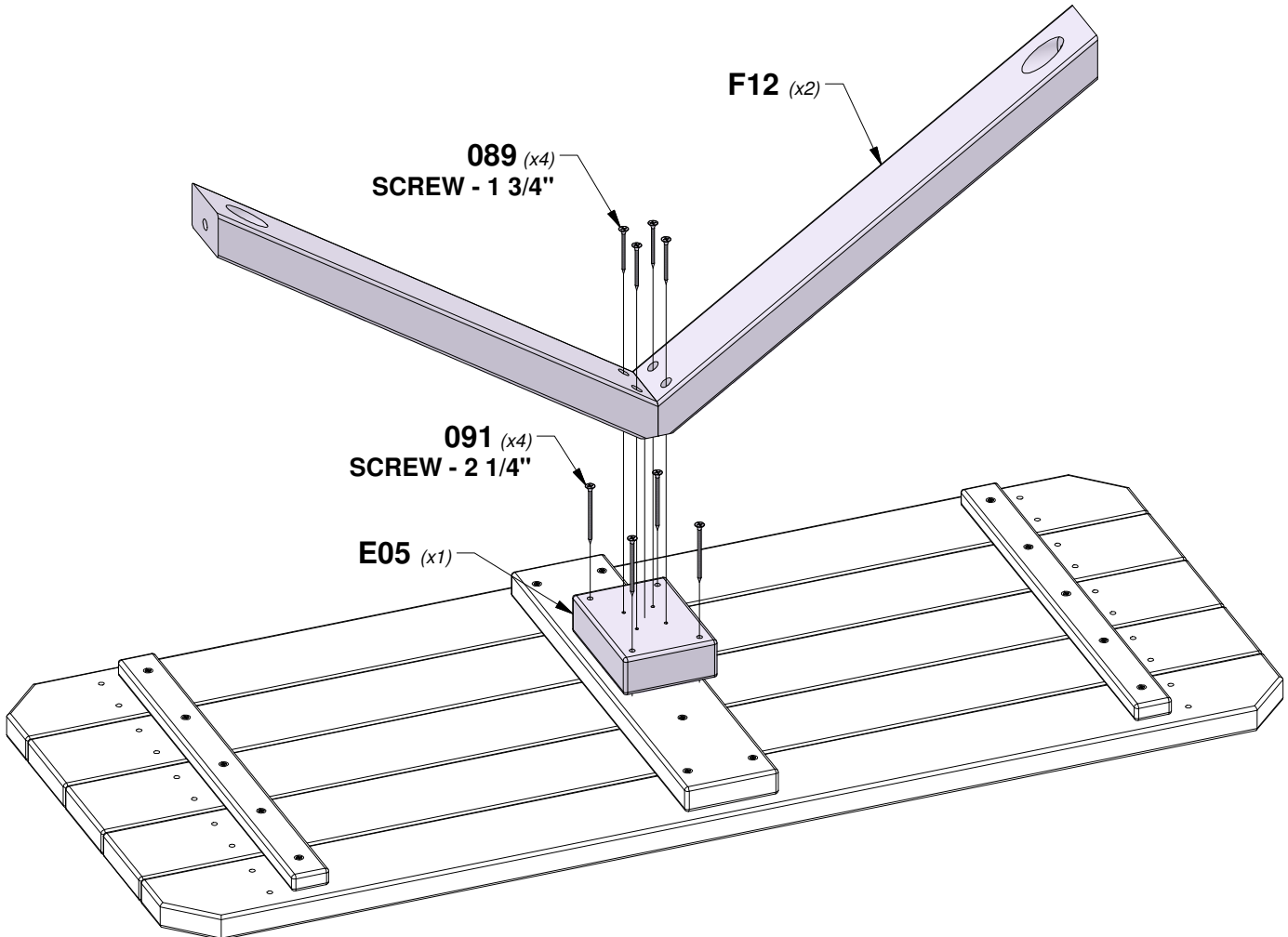
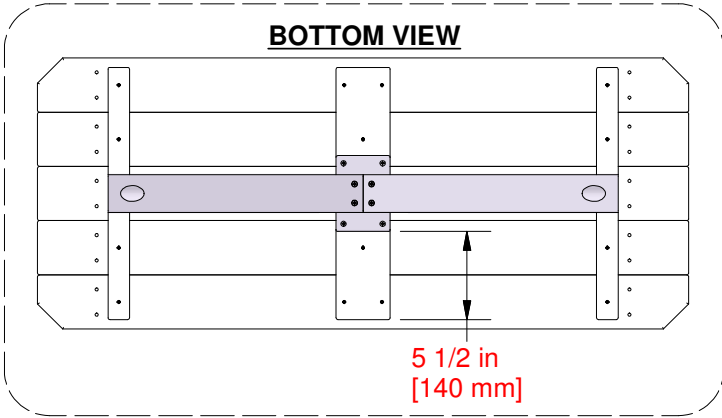



# STEP 3 - PICNIC TABLE

QTY	PART NUMBER	DESCRIPTION
2	H100027	LAG SCREW WH 5/16x2
2	H100030	WASHER LOCK EXT 8x19
20	H100089	SCREW PFH 8x1-3/4"

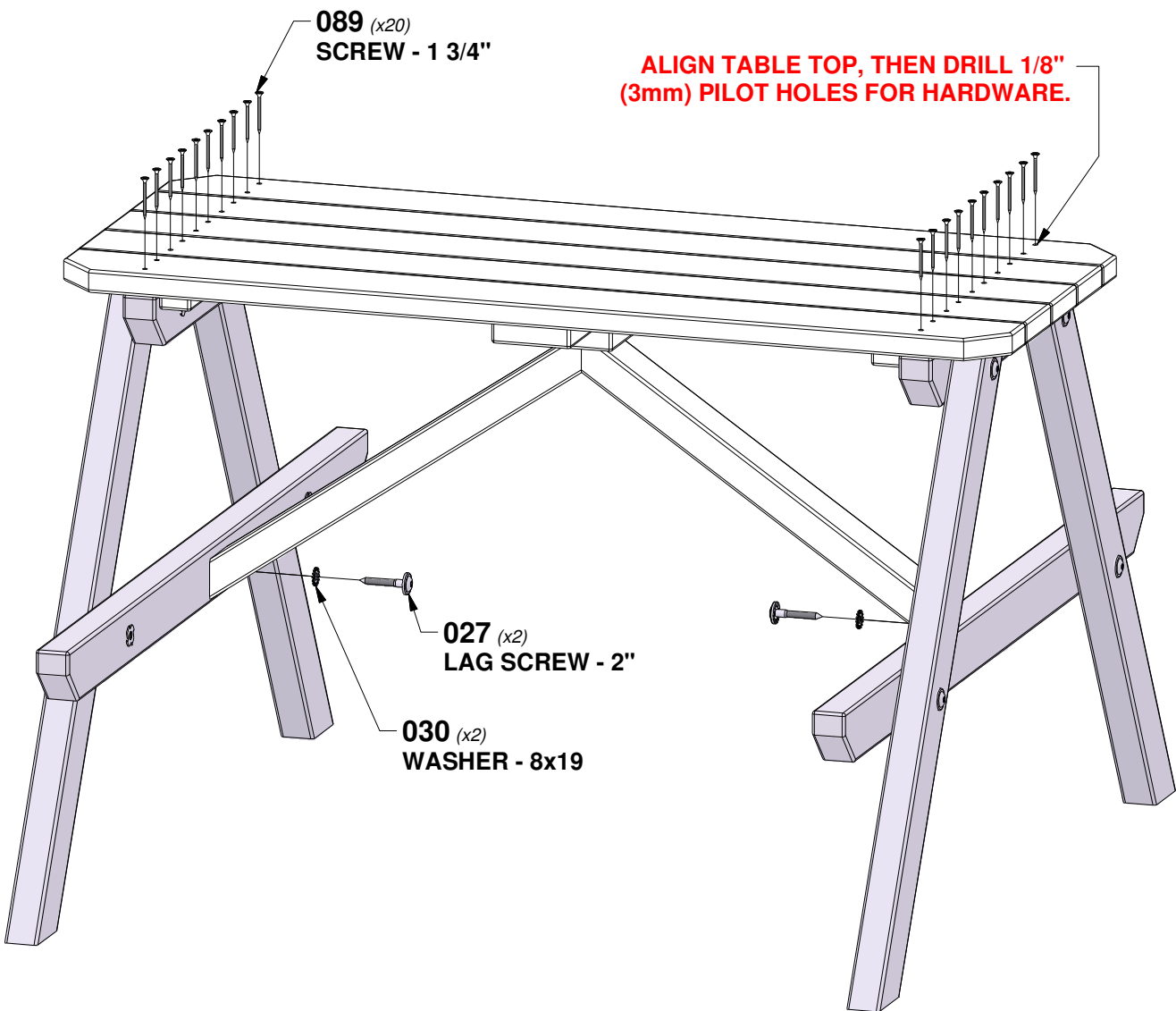
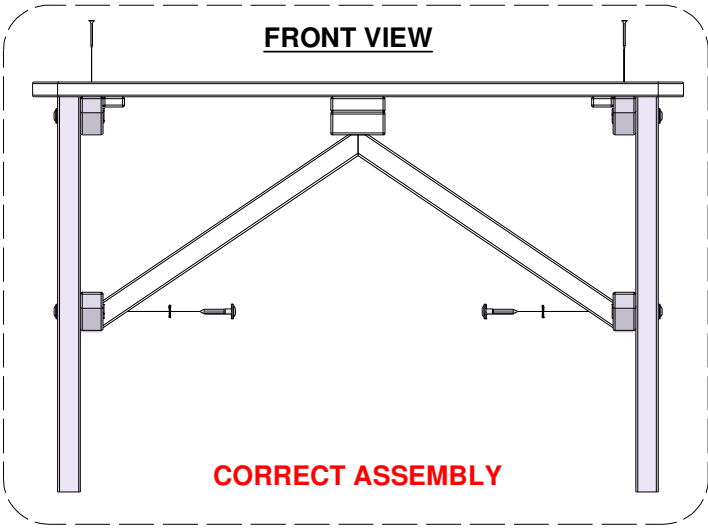

# STEP 4 - PICNIC TABLE

QTY	PART NUMBER	DESCRIPTION
16	H100089	SCREW PFH 8x1-3/4"



**TP2** | PICNIC TABLE SEAT - W2A03414  
 (x2) | 1 9/16"x6 3/4"x40 11/16" (40x172x1034)

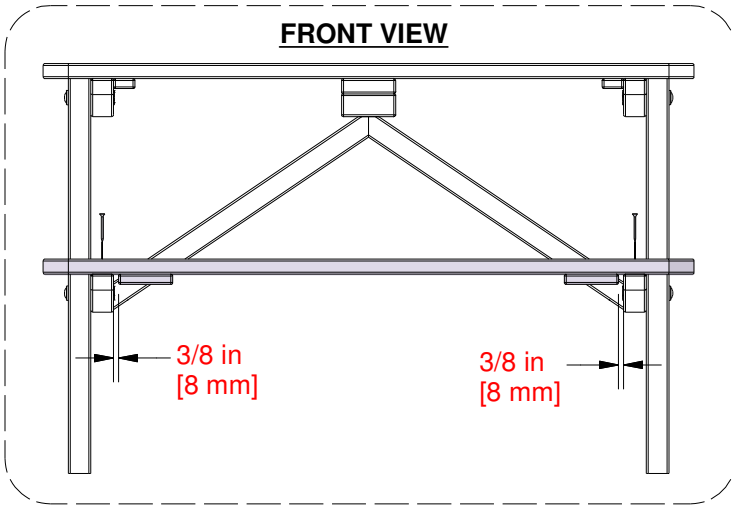

**ALIGN TABLE SEATS, THEN DRILL 1/8" (3mm) PILOT HOLES FOR HARDWARE.**

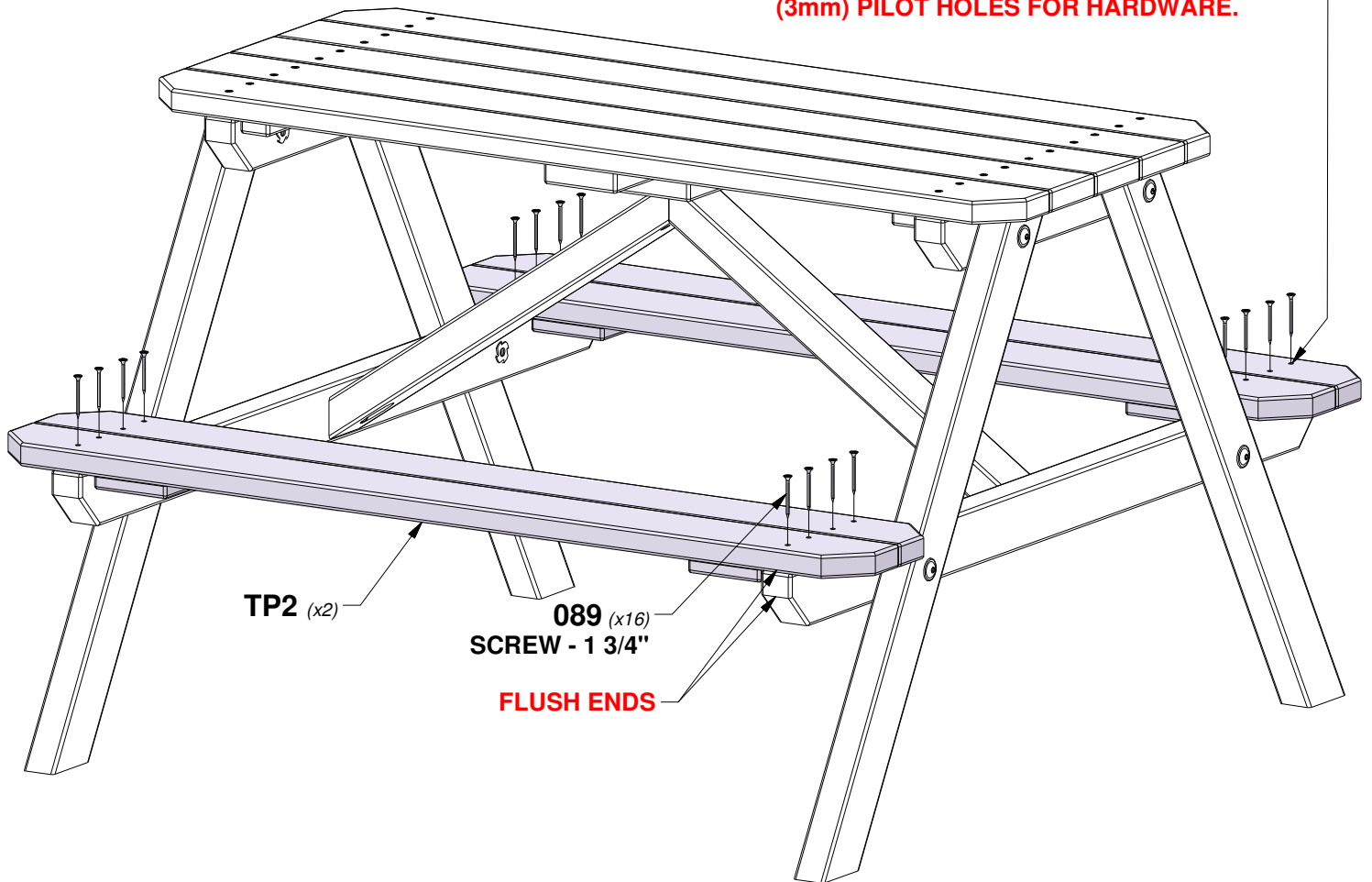

# STEP 1 - SWING BEAM ASSEMBLY

QTY	PART NUMBER	DESCRIPTION
10	H100192	NUT BARREL WH 5/16x7/8 BLK
10	H100416	BOLT WH 5/16x3 BLK

**A50** | SWING BEAM 2 POSITION - W4L16461  
(x1) 3 3/8"x5 1/4"x89 1/2" (86x134x2274)

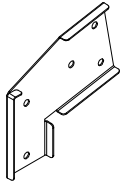

**A4M00617** | SWING BEAM  
EXTENSION  
BRACKET-LEFT  
(x1)

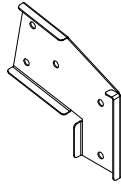

**A4M00618** | SWING BEAM  
EXTENSION  
BRACKET-RIGHT  
(x1)

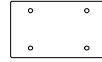

**A2** | SB 9" BLOCK - W4L16459  
(x1) 3 3/8"x5 1/4"x9" (86x134x228)

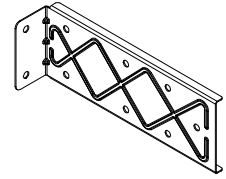

**A4M01679** | EXTENDED  
SWING BEAM  
BRACKET  
(x2)

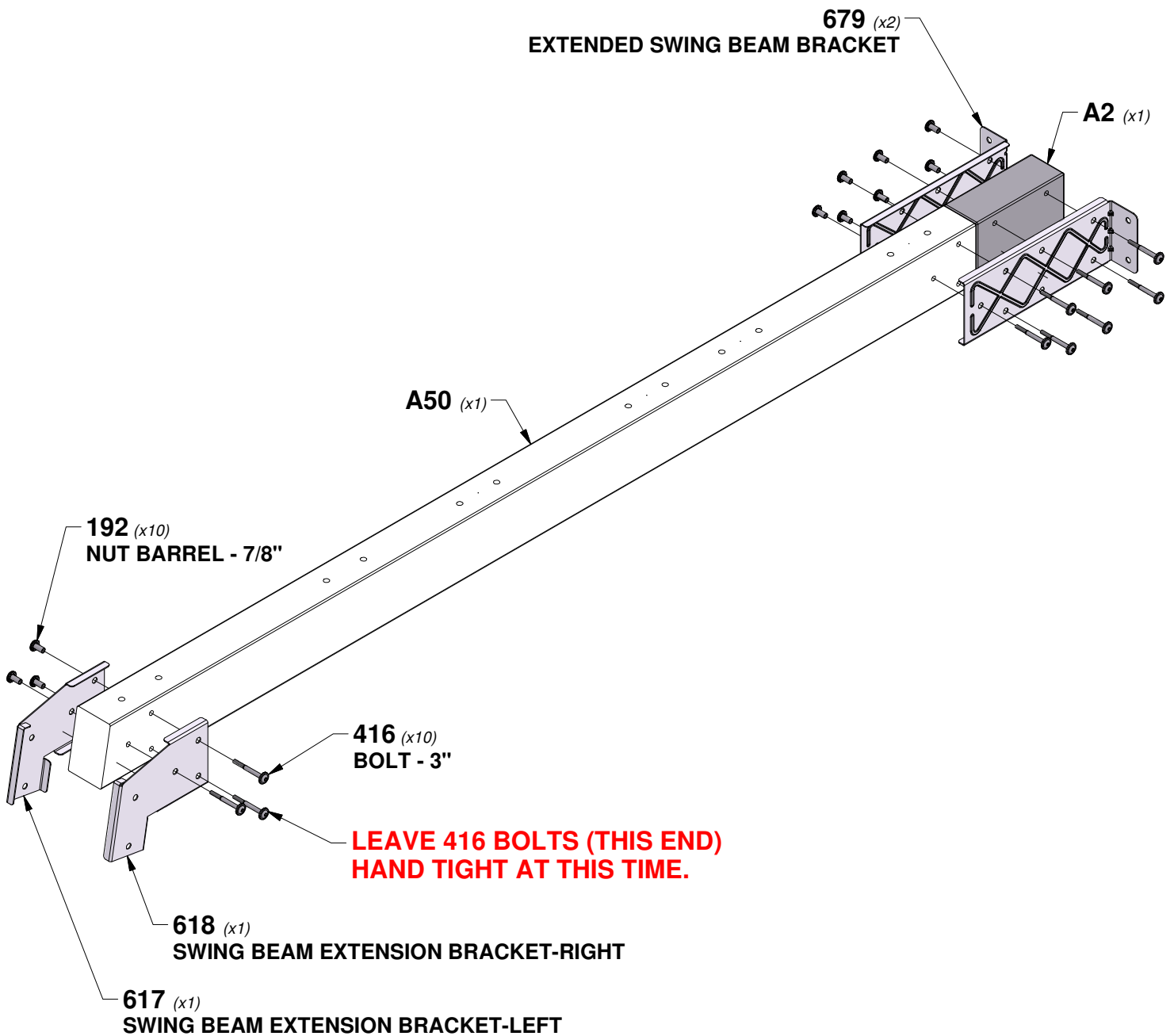

# STEP 2 - SWING BEAM ASSEMBLY

QTY	PART NUMBER	DESCRIPTION
12	H100073	T-NUT 3/8
12	H100102	WASHER FLAT 11x25
12	H100107	WASHER LOCK INT 10x18
12	H100654	BOLT HEX 3/8x5-1/2

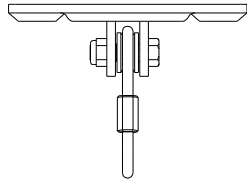

**A4M00505**  
(x6) | SWING HANGER

**TIP:**  
INSTALL T-NUTS IN WOOD FIRST

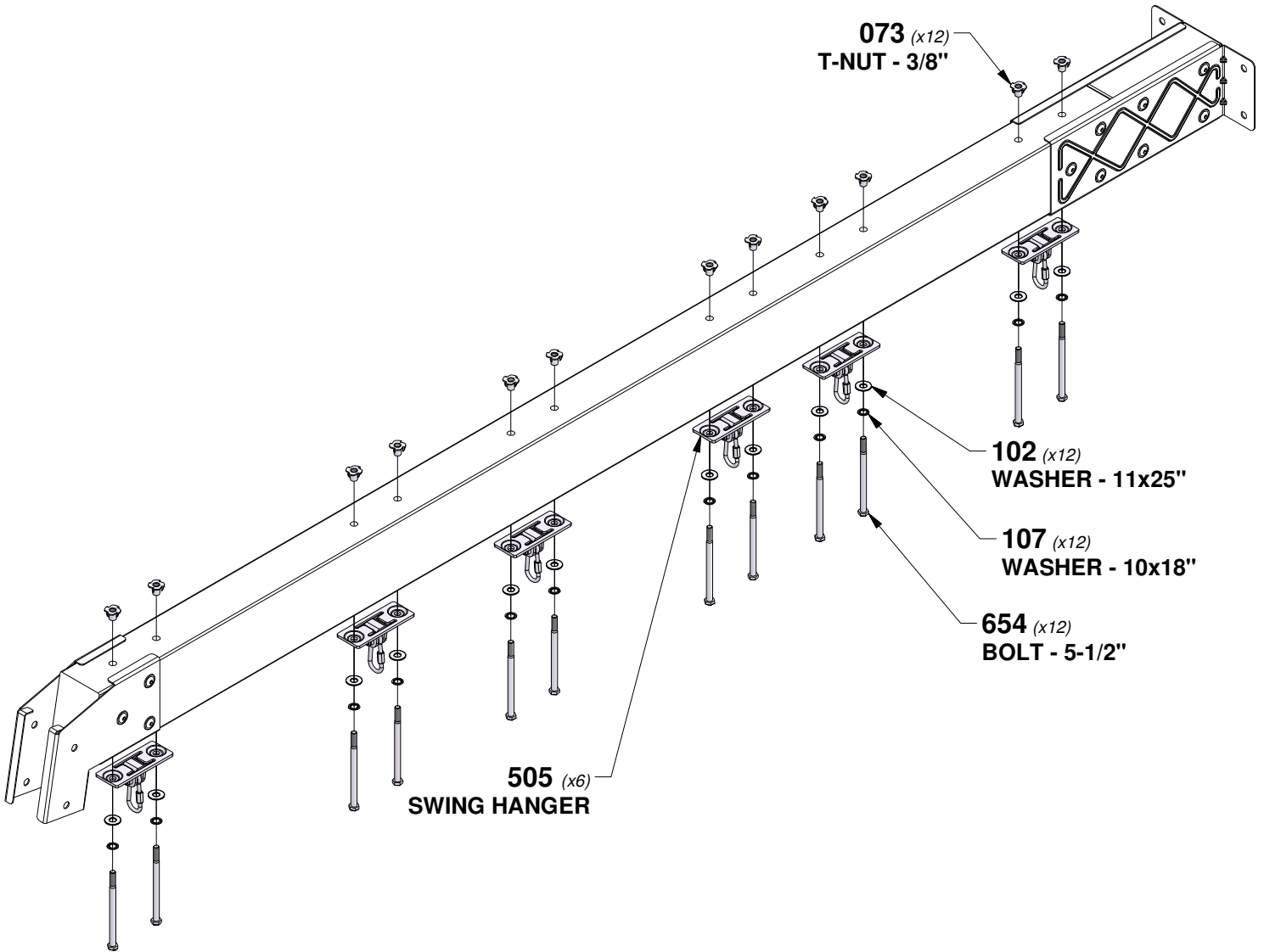

# STEP 3 - SWING BEAM ASSEMBLY

QTY	PART NUMBER	DESCRIPTION
4	H100070	SCREW PWH 8x3/4



**A100164** BYD ID TAG  
*(x1)* (LARGE) AGES  
3-10

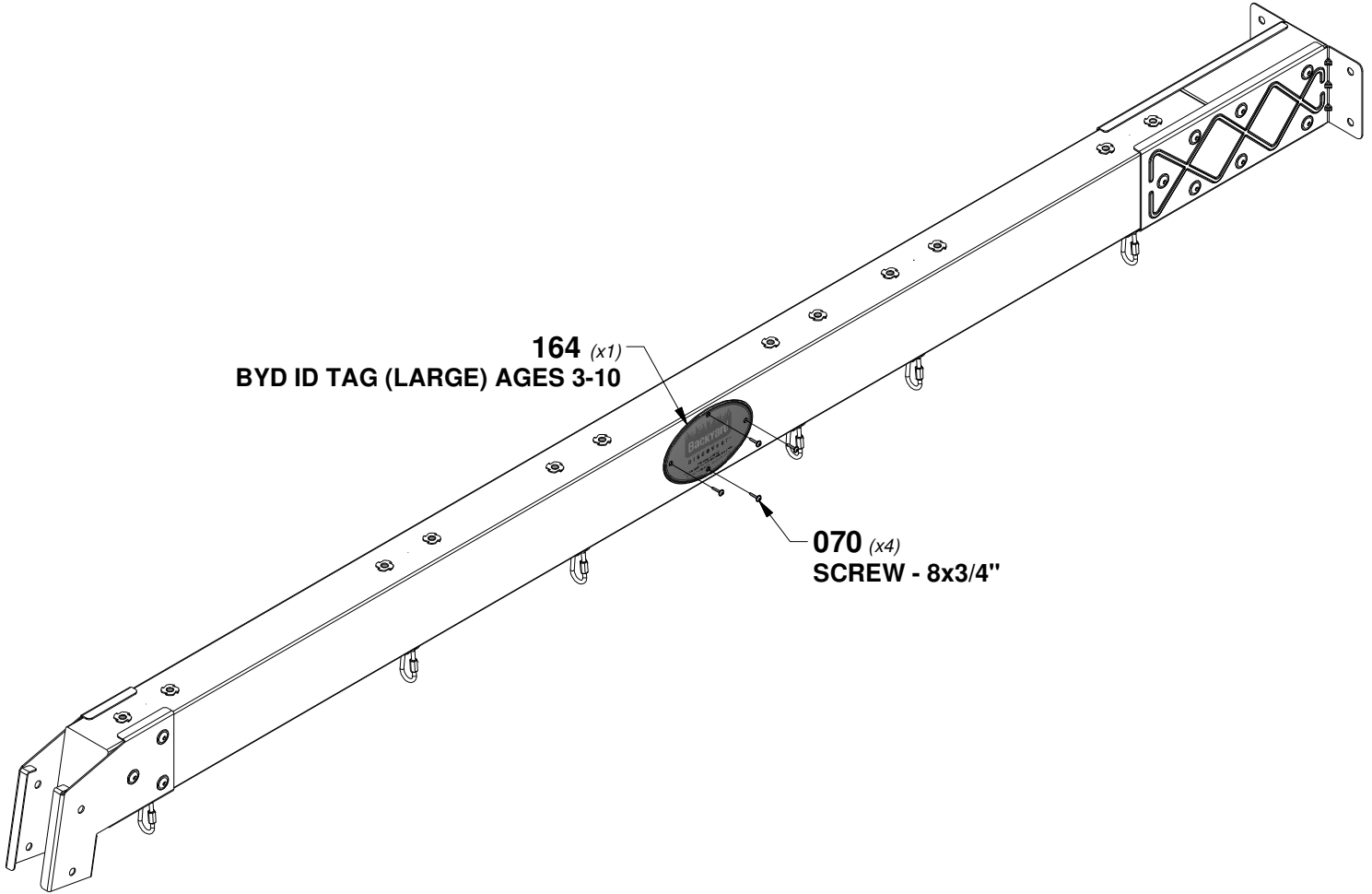

# STEP 4 - SWING BEAM ASSEMBLY

QTY	PART NUMBER	DESCRIPTION
6	H100379	T-NUT 5/16 BLK
4	H100416	BOLT WH 5/16x3 BLK
2	H100503	BOLT WH 5/16x3-1/2 BLK



**SP01** | SWING BEAM SUPPORT - W4L16462  
(x1) | 3 3/8"x3 3/8"x50" (86x86x1269)

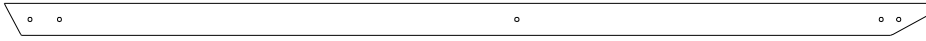

**B50** | ANGLE BRACE - W4L16463  
(x2) | 3"x3"x87 1/8" (76x76x2212)

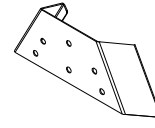

**A4M01498** | A-FRAME BRACKET  
(x1)

**TIP:**  
INSTALL T-NUTS IN WOOD FIRST

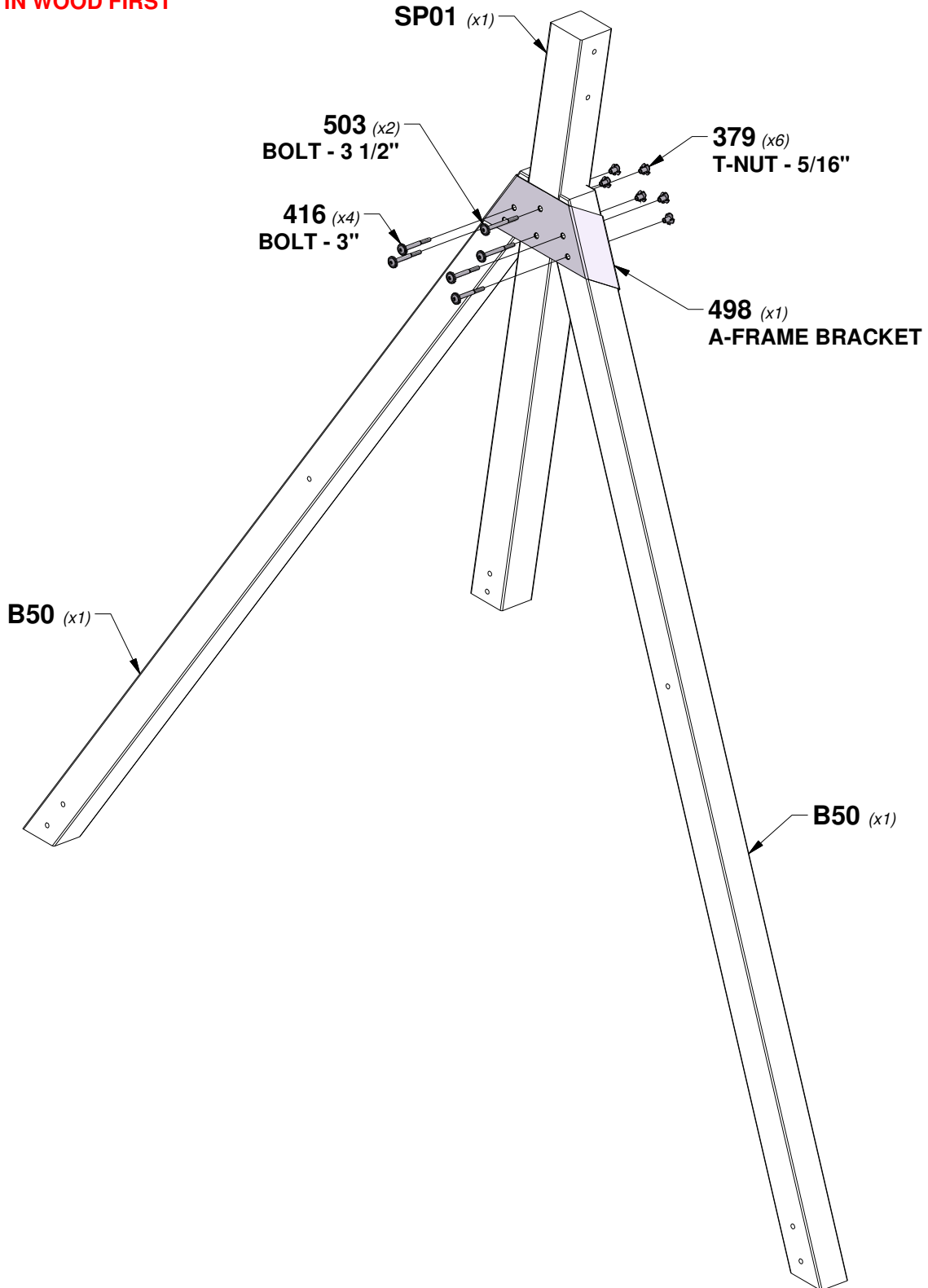

# STEP 5 - SWING BEAM ASSEMBLY

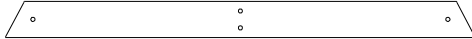

**E50** | END SUPPORT - W4L16464  
(x1) | 1 3/8"x3 3/8"x44 1/8" (36x86x1120)



**G50** | GROUND BOARD - W4L16465  
(x1) | 1"x5 1/4"x86 3/4" (24x134x2202)

QTY	PART NUMBER	DESCRIPTION
4	H100019	BOLT WH 5/16x3 3/4
8	H100030	WASHER LOCK EXT 8x19
8	H100074	T-NUT 5/16
2	H100166	BOLT WH 5/16x4 1/4
2	H100505	BOLT WH 5/16x4 3/4

**TIP:**  
INSTALL T-NUTS IN WOOD FIRST

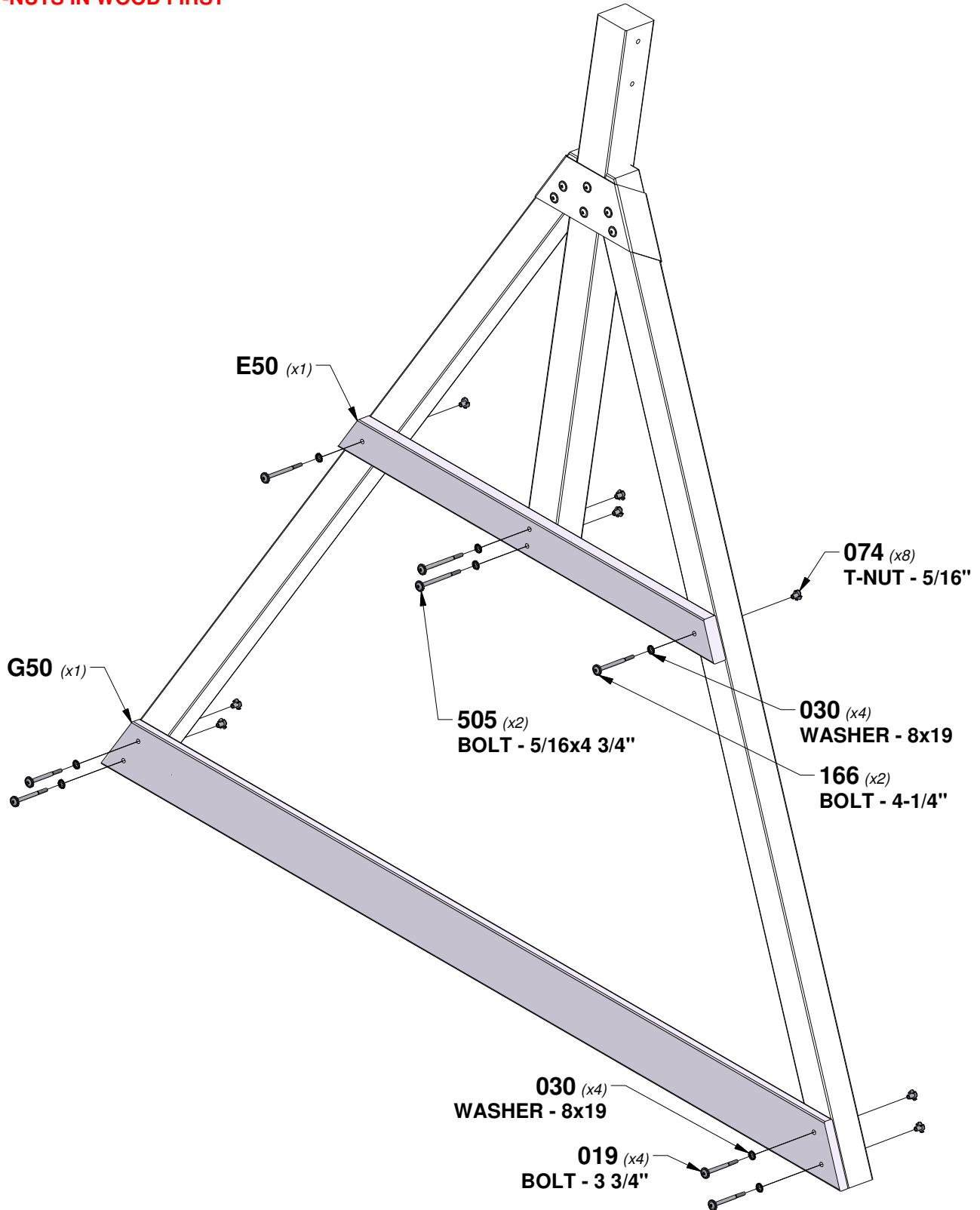

# STEP 6 - SWING BEAM ASSEMBLY

QTY	PART NUMBER	DESCRIPTION
2	H100192	NUT BARREL WH 5/16x7/8 BLK
2	H100416	BOLT WH 5/16x3 BLK

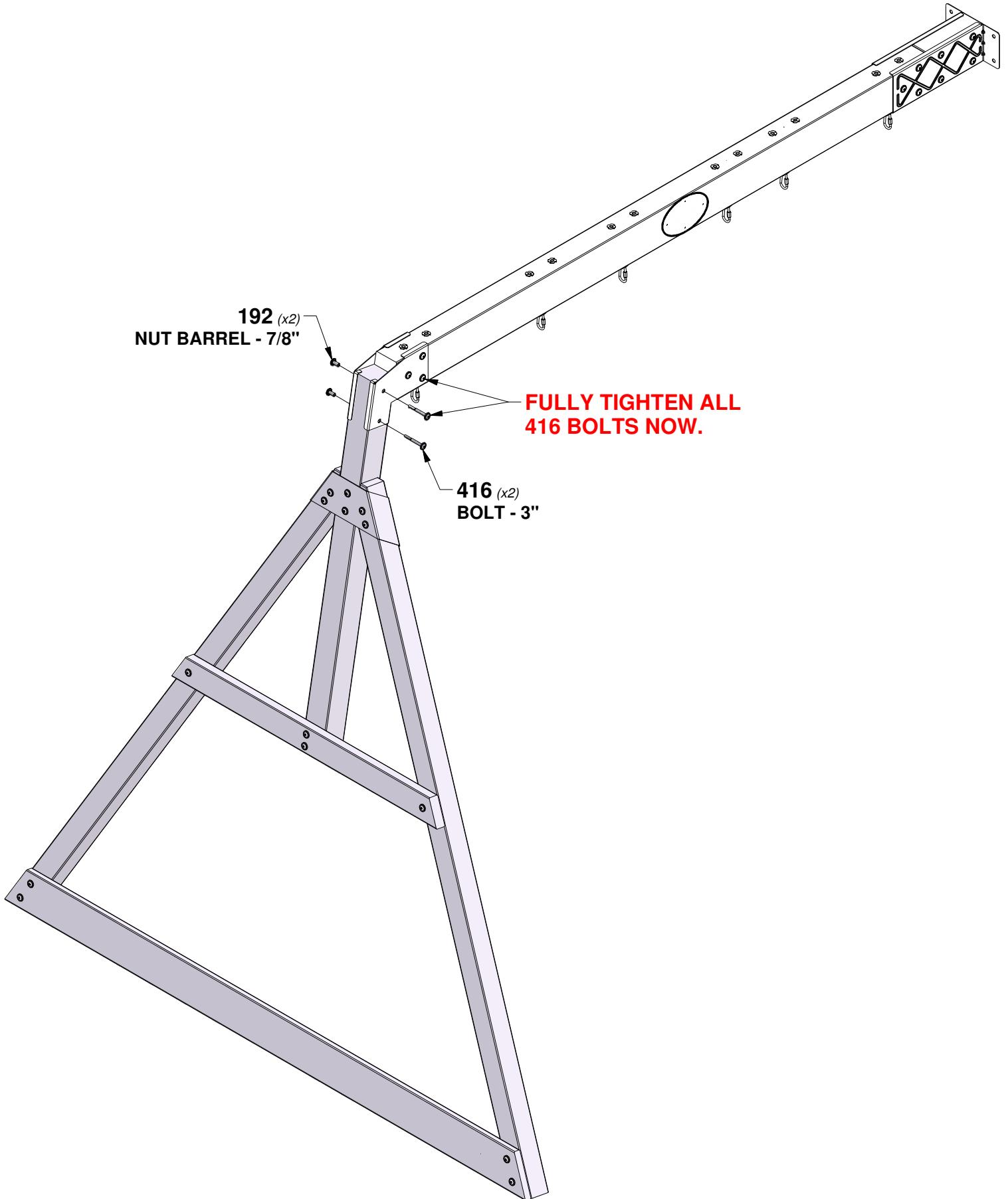



# STEP 1 - FORT ASSEMBLY

QTY	PART NUMBER	DESCRIPTION
10	H100019	BOLT WH 5/16x3 3/4
14	H100030	WASHER LOCK EXT 8x19
20	H100074	T-NUT 5/16
4	H100166	BOLT WH 5/16x4-1/4
2	H100416	BOLT WH 5/16x3 BLK



**G04** | WALL RAIL - W4L16443  
(x1) | 1"x5 1/4"x50 3/8" (24x134x1280)

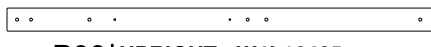

**B06** | UPRIGHT - W4L16425  
(x2) | 3"x3"x55 1/2" (76x76x1410)



**H08** | WALL RAIL - W4L16454  
(x1) | 1"x3 3/8"x52 1/4" (24x86x1328)



**D01** | WALL RAIL - W4L16426  
(x1) | 1 3/8"x5 1/4"x50 3/8" (36x134x1280)



**Q01** | FLOOR RAIL - W4L16173  
(x1) | 1"x4 3/8"x67 5/8" (24x112x1718)

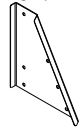

**A4M01481** | A-FRAME  
BRACKET-RT  
(x1)

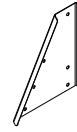

**A4M01482** | A-FRAME  
BRACKET-LT  
(x1)

**TIP:**  
INSTALL T-NUTS IN WOOD FIRST

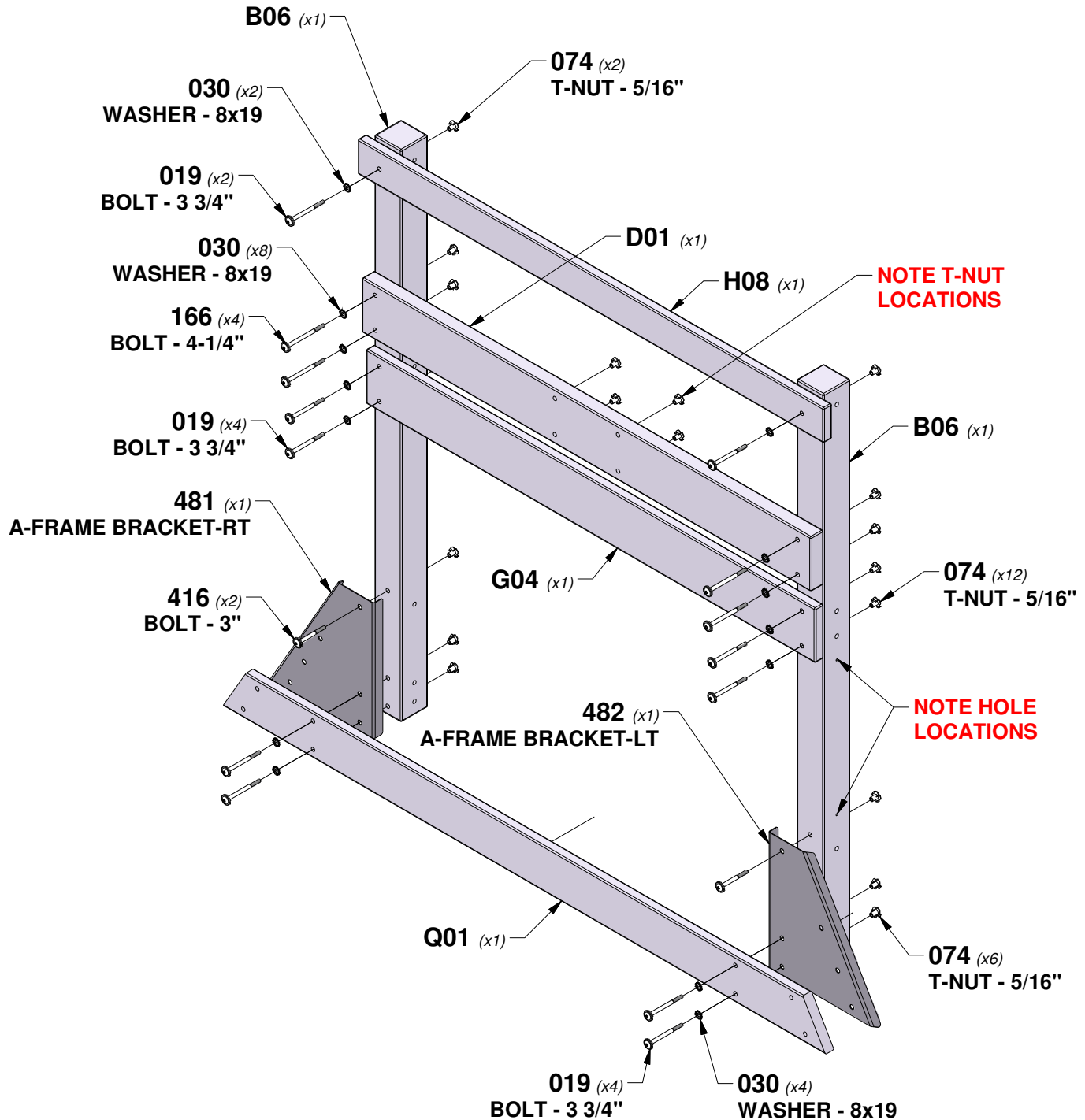

# STEP 2 - FORT ASSEMBLY

QTY	PART NUMBER	DESCRIPTION
4	H100019	BOLT WH 5/16x3 3/4
2	H100022	BOLT WH 5/16x5
6	H100030	WASHER LOCK EXT 8x19
6	H100074	T-NUT 5/16

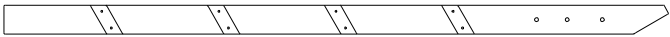

**B13** | LEG - W4L16476  
(x1) | 3"x3"x69 1/4" (76x76x1760)

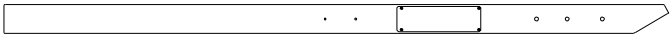

**B03** | LEG - W2A03278  
(x1) | 3"x3"x79 3/8" (76x76x2015)

**TIP:**  
INSTALL T-NUTS IN WOOD FIRST

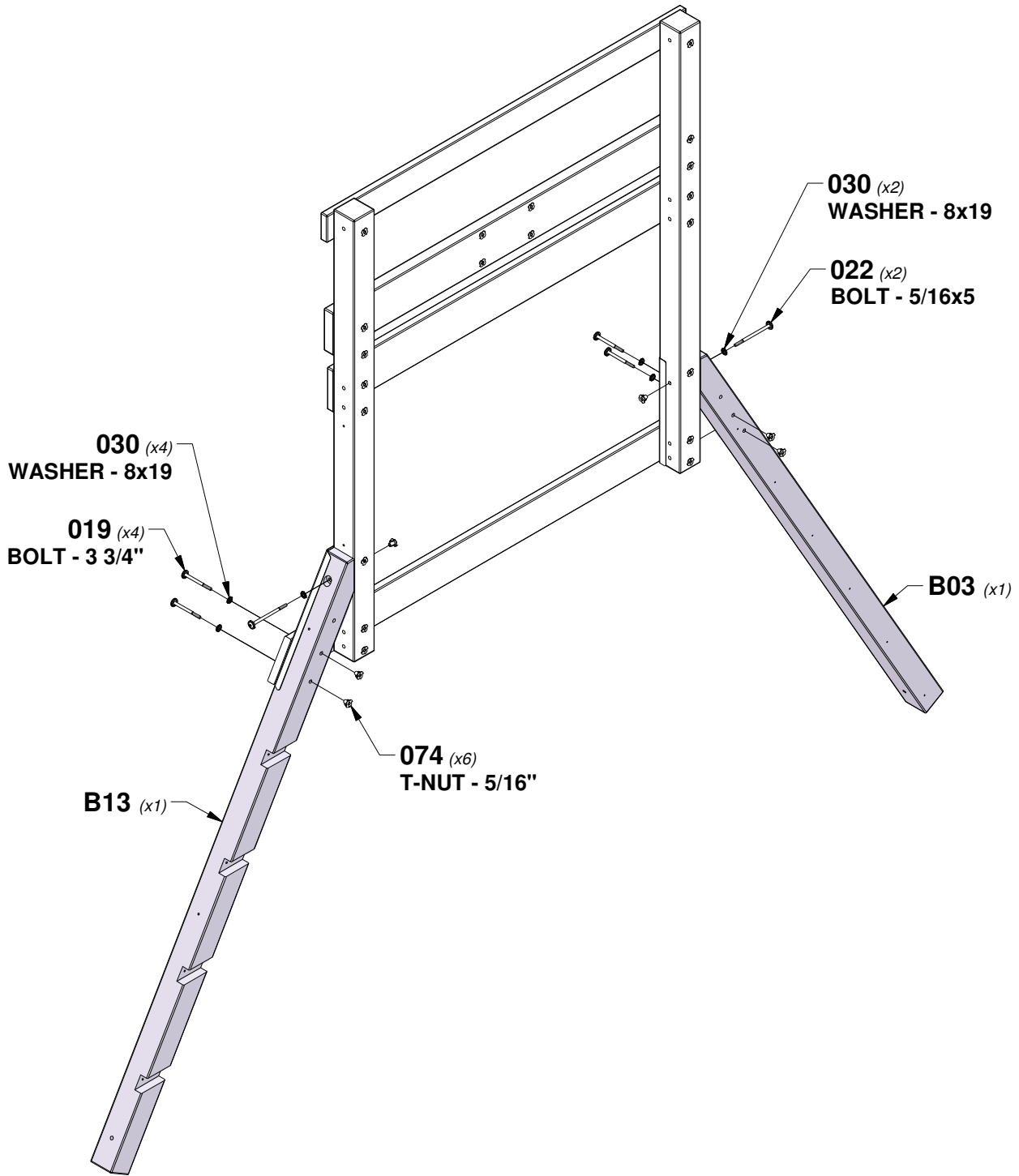

# STEP 3 - FORT ASSEMBLY

QTY	PART NUMBER	DESCRIPTION
10	H100019	BOLT WH 5/16x3 3/4
10	H100030	WASHER LOCK EXT 8x19
12	H100074	T-NUT 5/16
2	H100416	BOLT WH 5/16x3 BLK

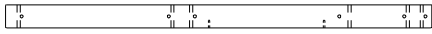

**B10** UPRIGHT - W4L16435  
(x2) 3"x3"x55 1/2" (76x76x1410)



**G02** WALL RAIL - W4L16423  
(x1) 1"x5 1/4"x50 3/8" (24x134x1280)



**H08** WALL RAIL - W4L16454  
(x1) 1"x3 3/8"x52 1/4" (24x86x1328)



**Q01** FLOOR RAIL - W4L16173  
(x1) 1"x4 3/8"x67 5/8" (24x112x1718)

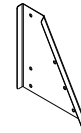

**A4M01481** A-FRAME  
(x1) BRACKET-RT

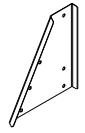

**A4M01482** A-FRAME  
(x1) BRACKET-LT

**TIP:**  
INSTALL T-NUTS IN WOOD FIRST

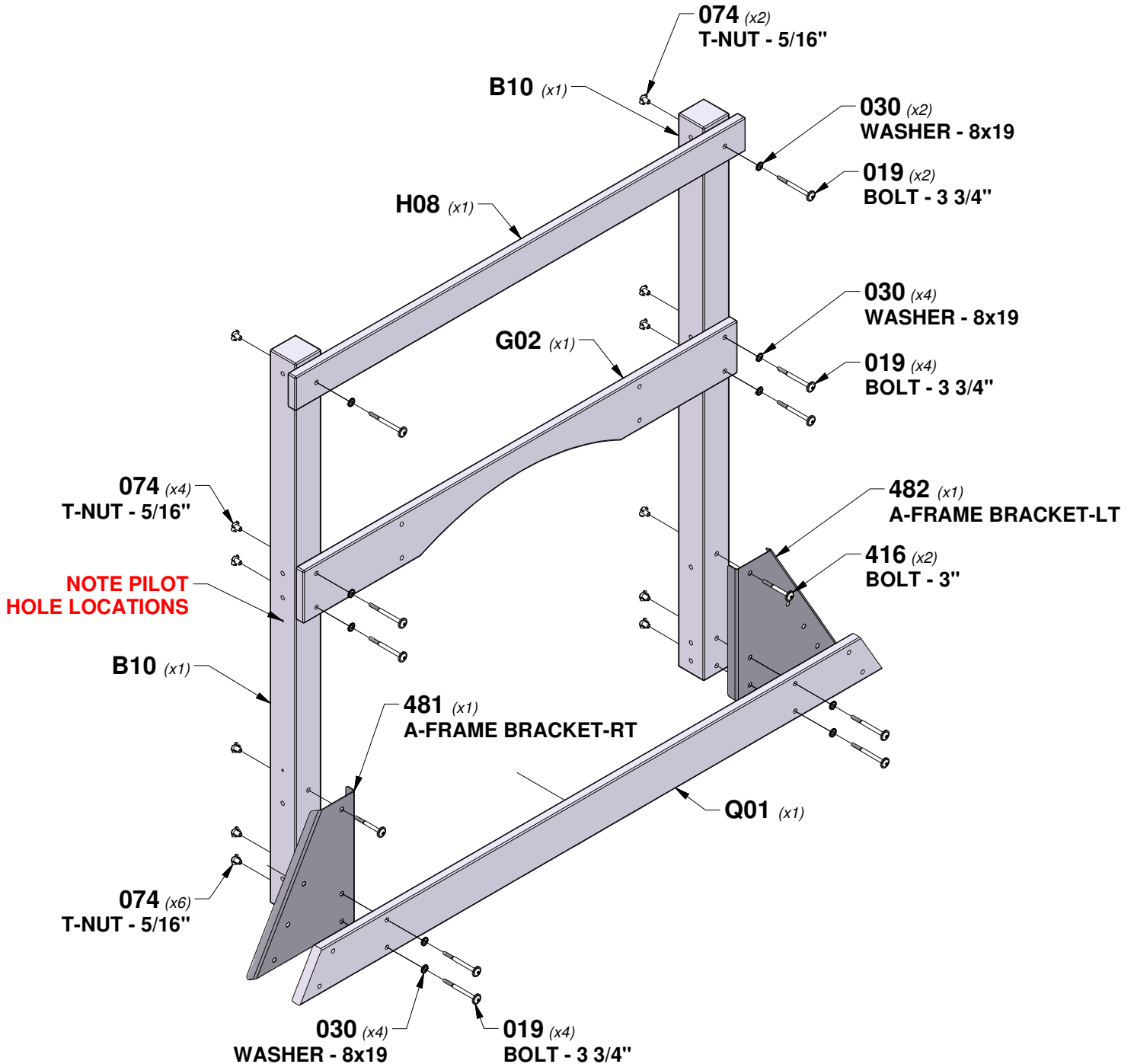

# STEP 4 - FORT ASSEMBLY

QTY	PART NUMBER	DESCRIPTION
4	H100019	BOLT WH 5/16x3 3/4
2	H100022	BOLT WH 5/16x5
6	H100030	WASHER LOCK EXT 8x19
6	H100074	T-NUT 5/16

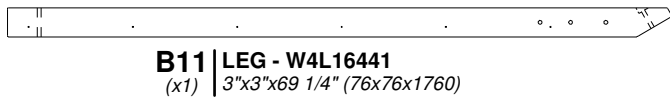
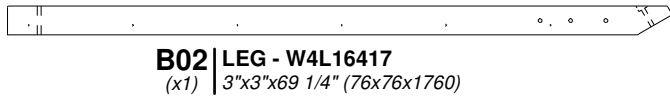

**TIP:**  
**INSTALL T-NUTS IN WOOD FIRST**

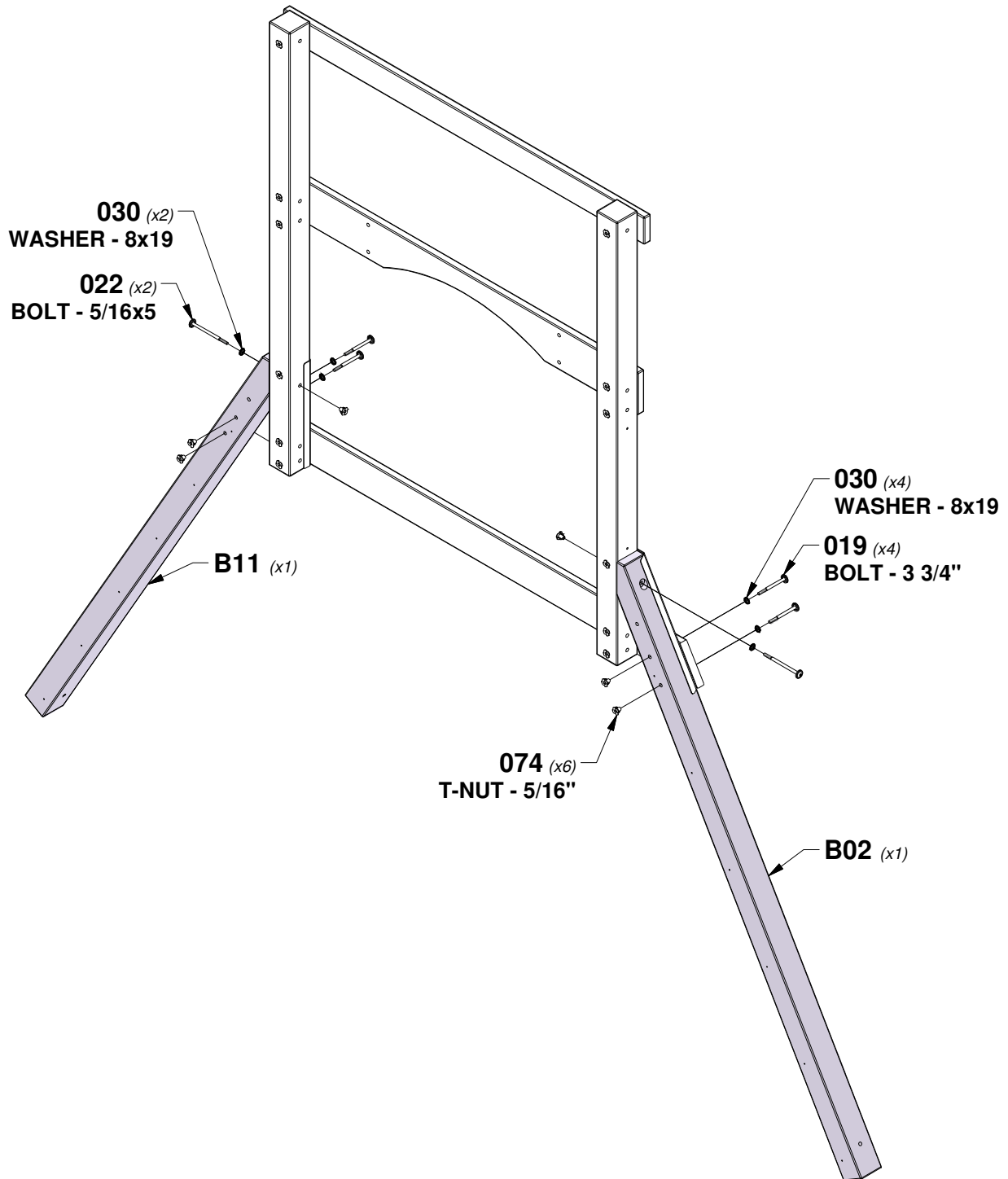

# STEP 5 - FORT ASSEMBLY

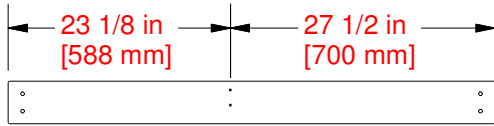

**Q03** | FLOOR RAIL - W4L16421  
(x1) 1"x4 3/8"x50 3/4" (24x112x1288)

QTY	PART NUMBER	DESCRIPTION
2	H100019	BOLT WH 5/16x3 3/4
2	H100030	WASHER LOCK EXT 8x19
2	H100074	T-NUT 5/16

**TIP:**  
**INSTALL T-NUTS IN WOOD FIRST**

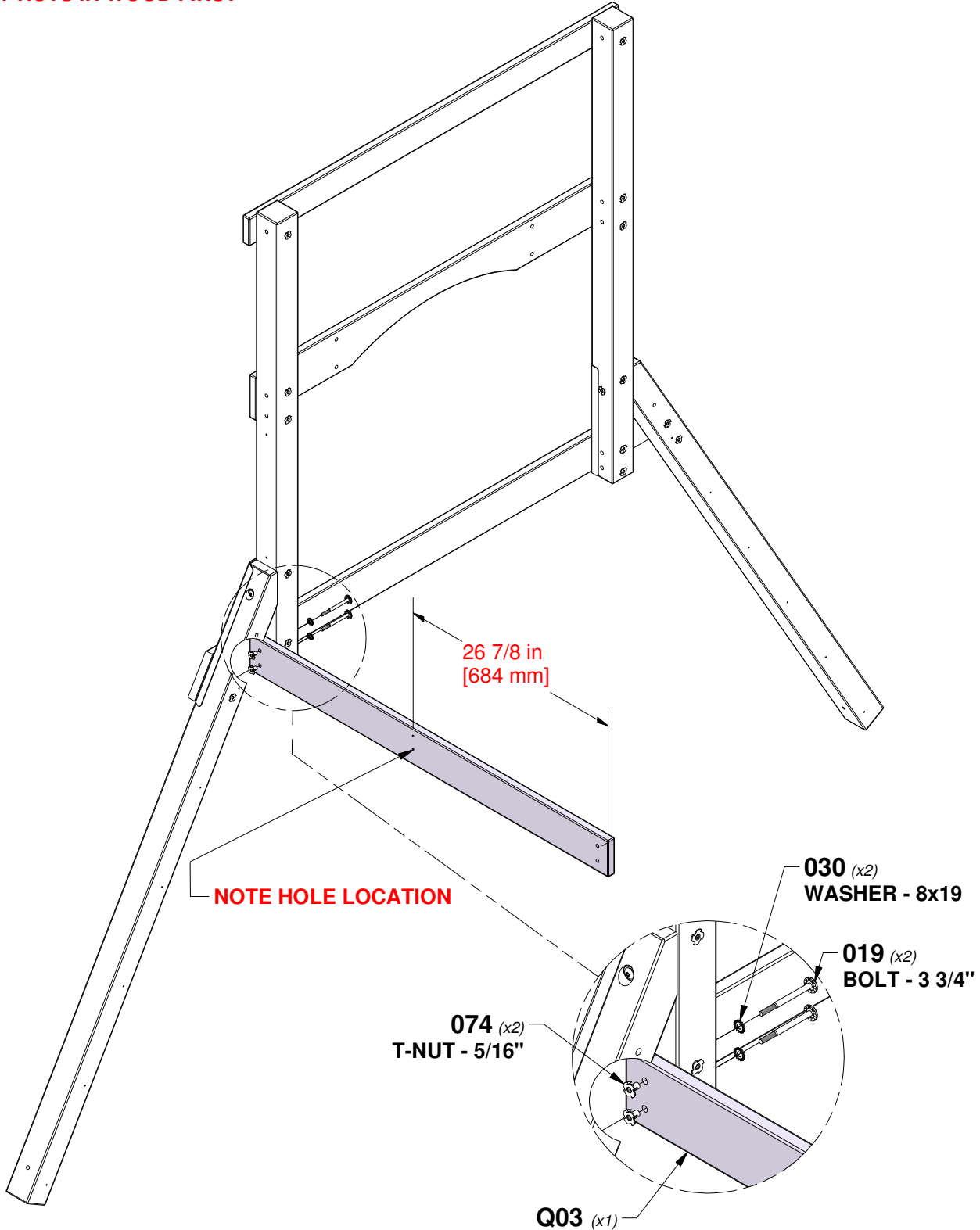

# STEP 6 - FORT ASSEMBLY

QTY	PART NUMBER	DESCRIPTION
2	H100019	BOLT WH 5/16x3 3/4
2	H100030	WASHER LOCK EXT 8x19
2	H100074	T-NUT 5/16

**TIP:**  
**INSTALL T-NUTS IN WOOD FIRST**

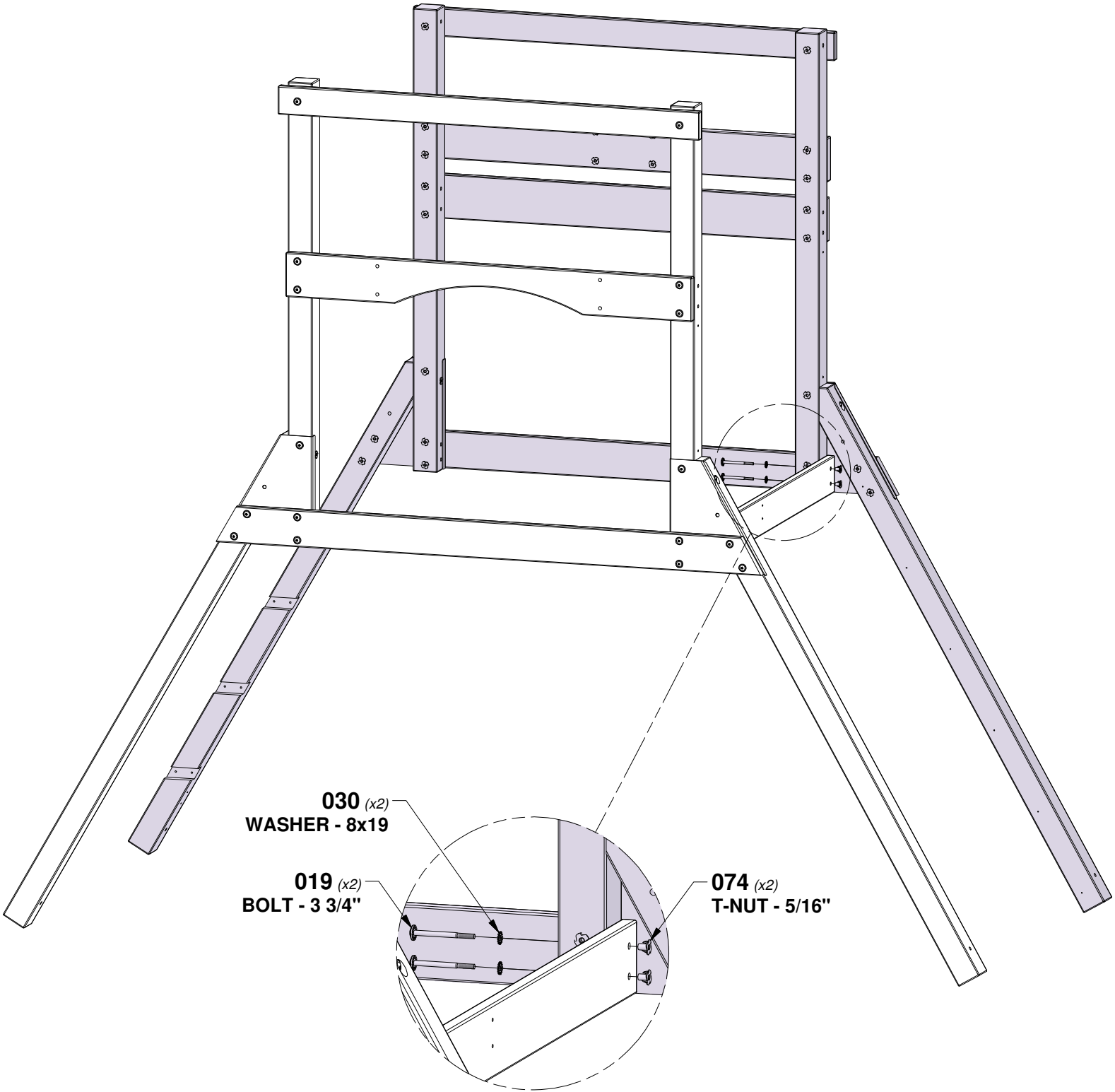

# STEP 7 - FORT ASSEMBLY



**Q02** | FLOOR RAIL - W4L16418  
 (x1) | 1"x4 3/8"x50 3/4" (24x112x1288)

QTY	PART NUMBER	DESCRIPTION
4	H100019	BOLT WH 5/16x3 3/4
4	H100030	WASHER LOCK EXT 8x19
4	H100074	T-NUT 5/16

**TIP:**  
**INSTALL T-NUTS IN WOOD FIRST**

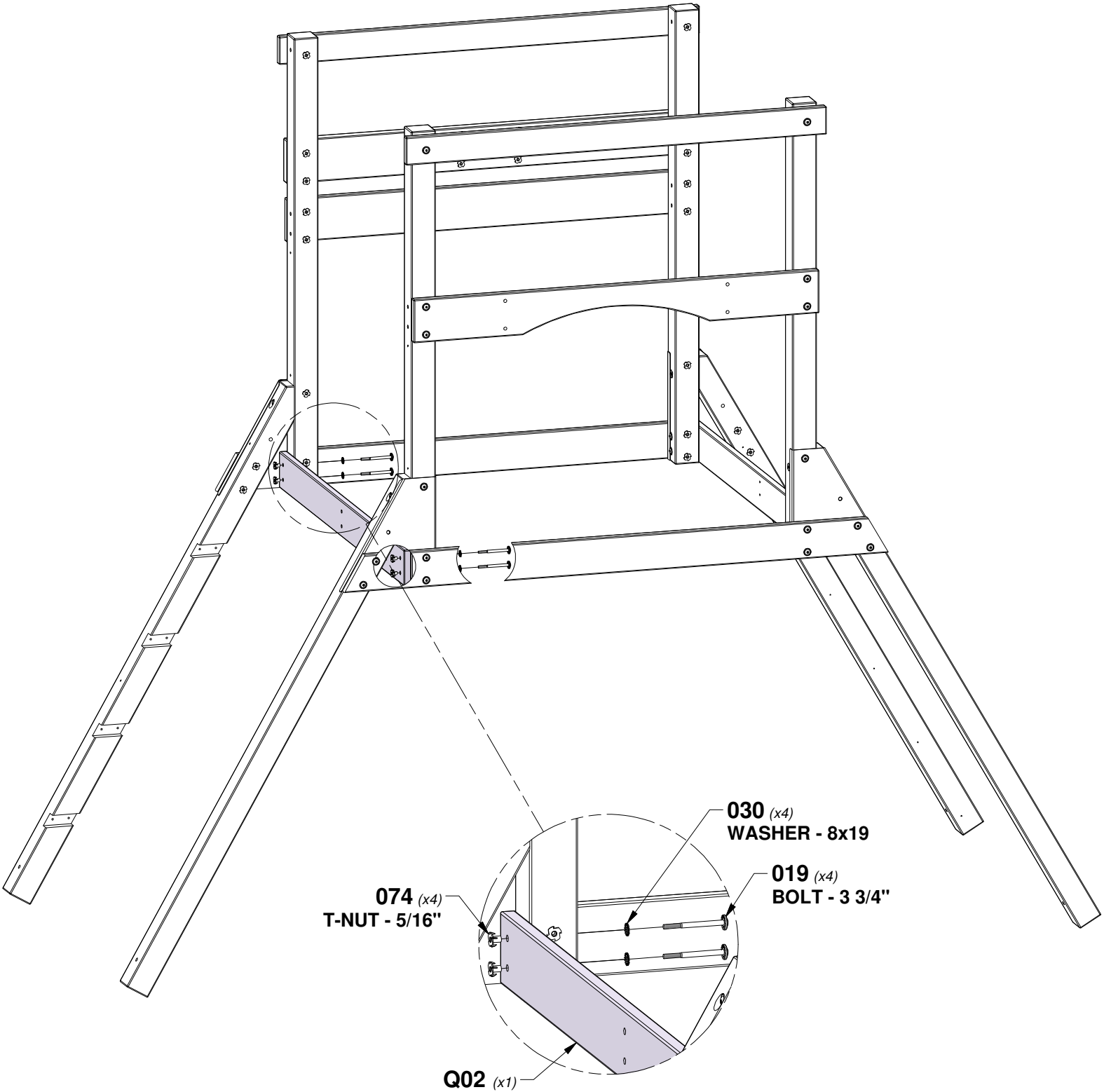

# STEP 8 - FORT ASSEMBLY

QTY	PART NUMBER	DESCRIPTION
4	H100023	BOLT WH 5/16X6
4	H100030	WASHER LOCK EXT 8x19
4	H100074	T-NUT 5/16

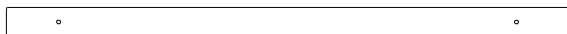

**B12** | GROUND BOARD - W4L16446  
(x1) | 3"x3"x58 5/8" (76x76x1488)



**B07** | GROUND BOARD - W4L16427  
(x1) | 3"x3"x58 5/8" (76x76x1488)

**TIP:**  
INSTALL T-NUTS IN WOOD FIRST

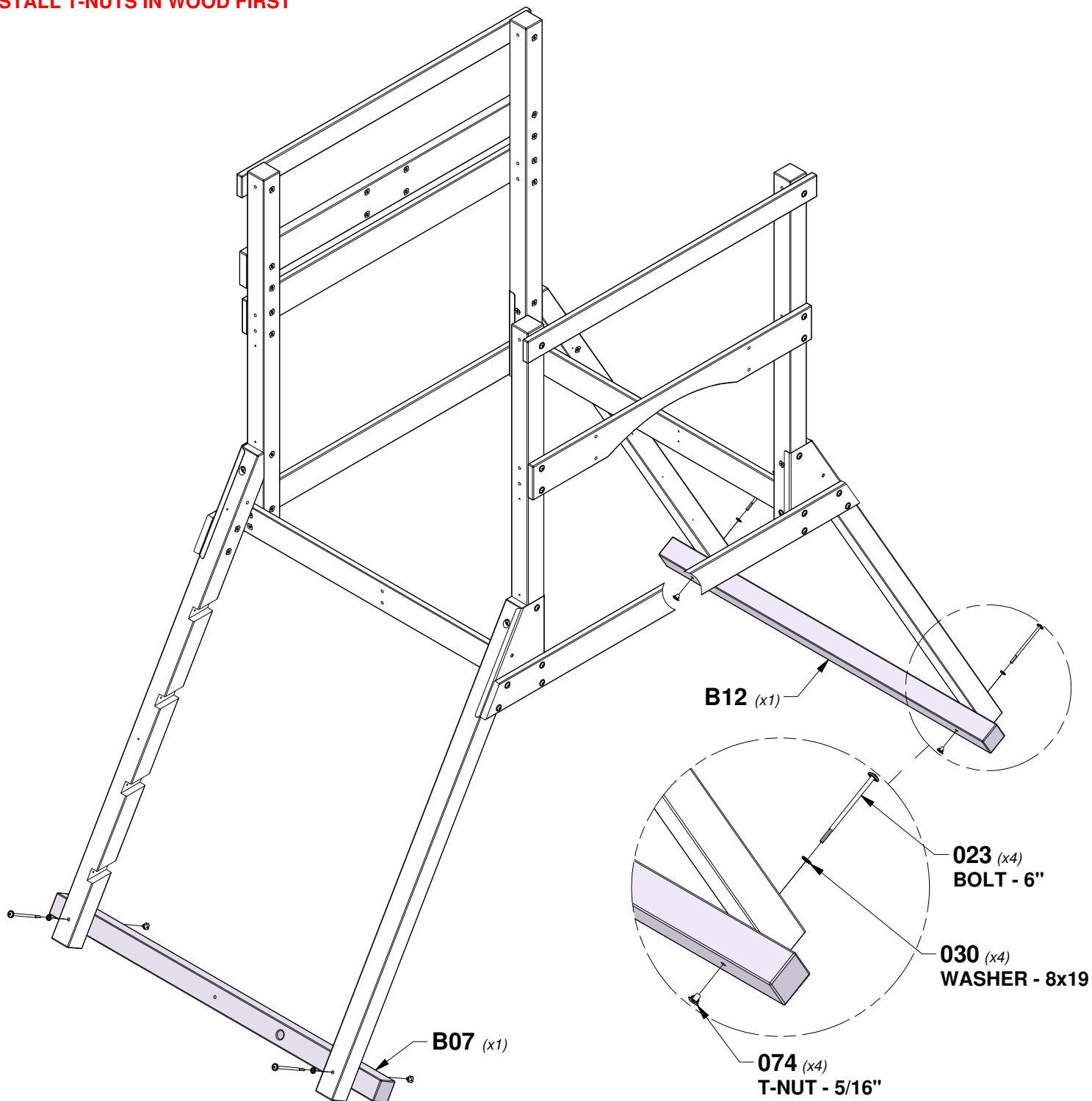



# STEP 9 - FORT ASSEMBLY



**B04** UPRIGHT - W4L16419  
(x1) | 3"x3"x35" (76x76x888)

QTY	PART NUMBER	DESCRIPTION
2	H100019	BOLT WH 5/16x3 3/4
2	H100030	WASHER LOCK EXT 8x19
2	H100074	T-NUT 5/16

**TIP:**  
INSTALL T-NUTS IN WOOD FIRST

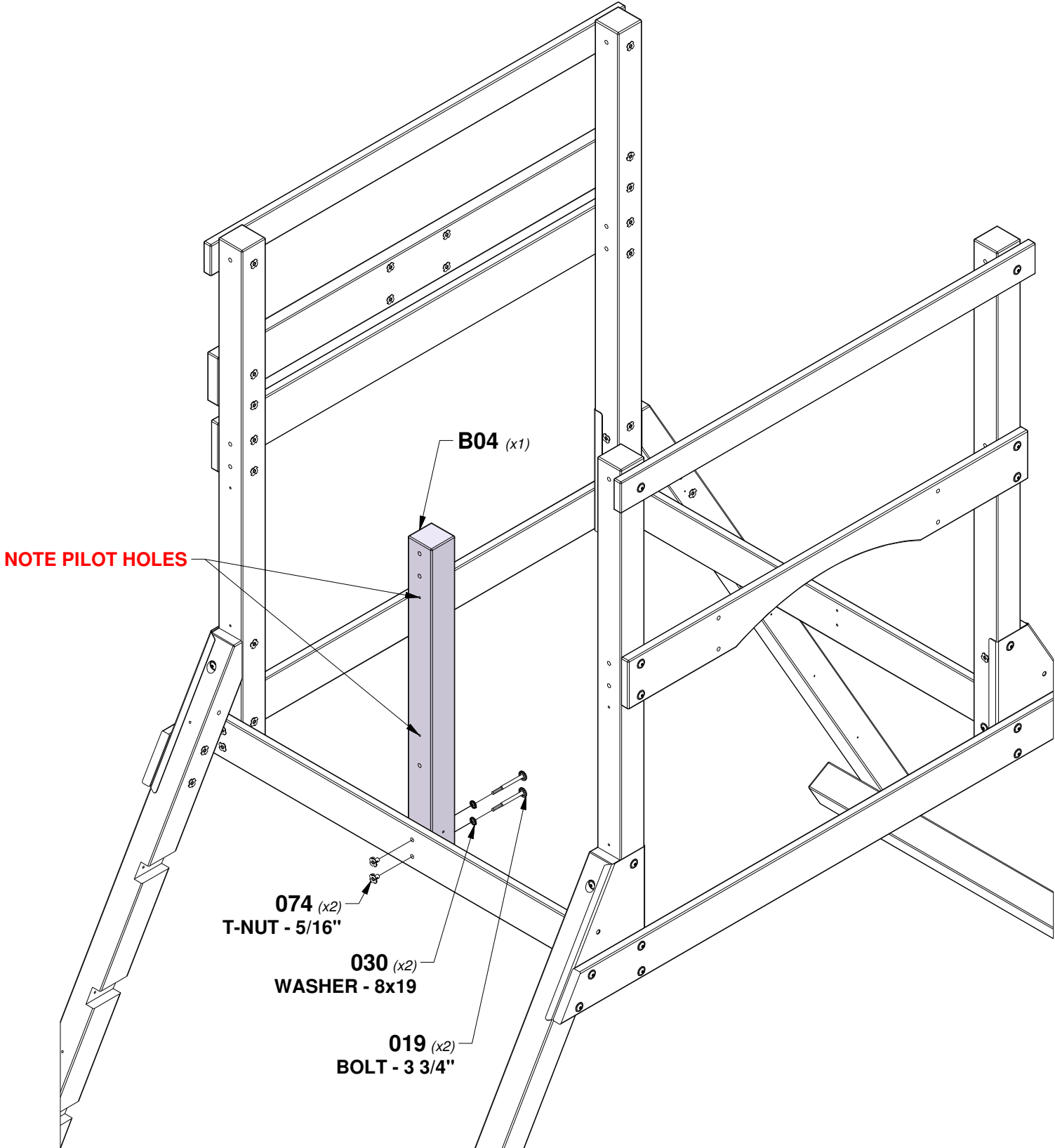

# STEP 10 - FORT ASSEMBLY

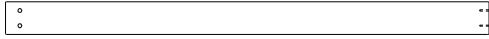

**E01** | FLOOR JOIST - W4L16420  
 (x1) | 1 3/8"x3 3/8"x50 3/8" (36x86x1280)

QTY	PART NUMBER	DESCRIPTION
2	H100029	LAG SCREW WH 5/16x3
2	H100030	WASHER LOCK EXT 8x19
2	H100092	SCREW PFH 8x3

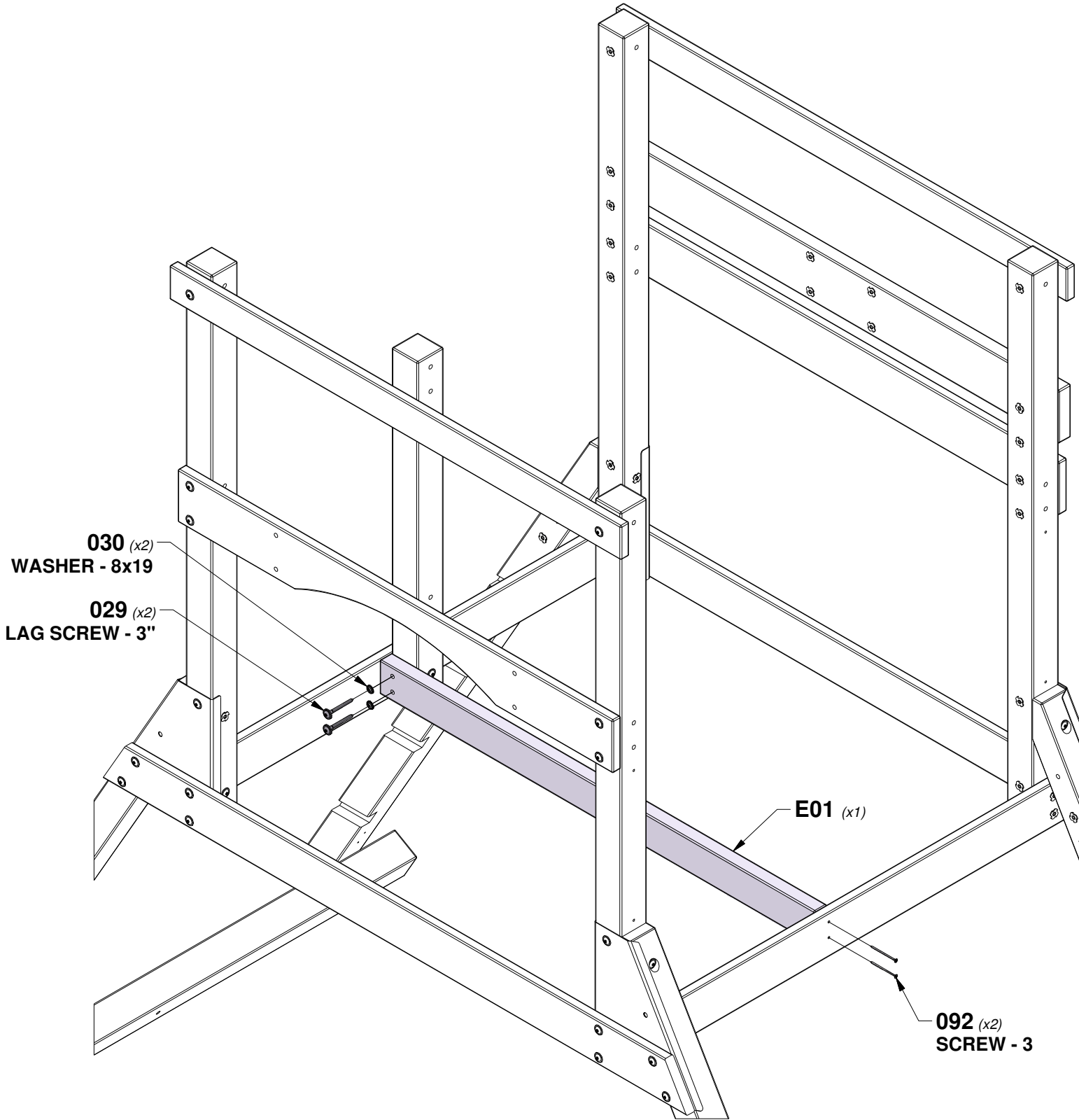

# STEP 11 - FORT ASSEMBLY

QTY	PART NUMBER	DESCRIPTION
10	H100091	SCREW PFH 8x2 1/4



**H03** FLOOR RAIL - W4L16430  
(x5) 1"x3"x3 3/8" (24x76x86)

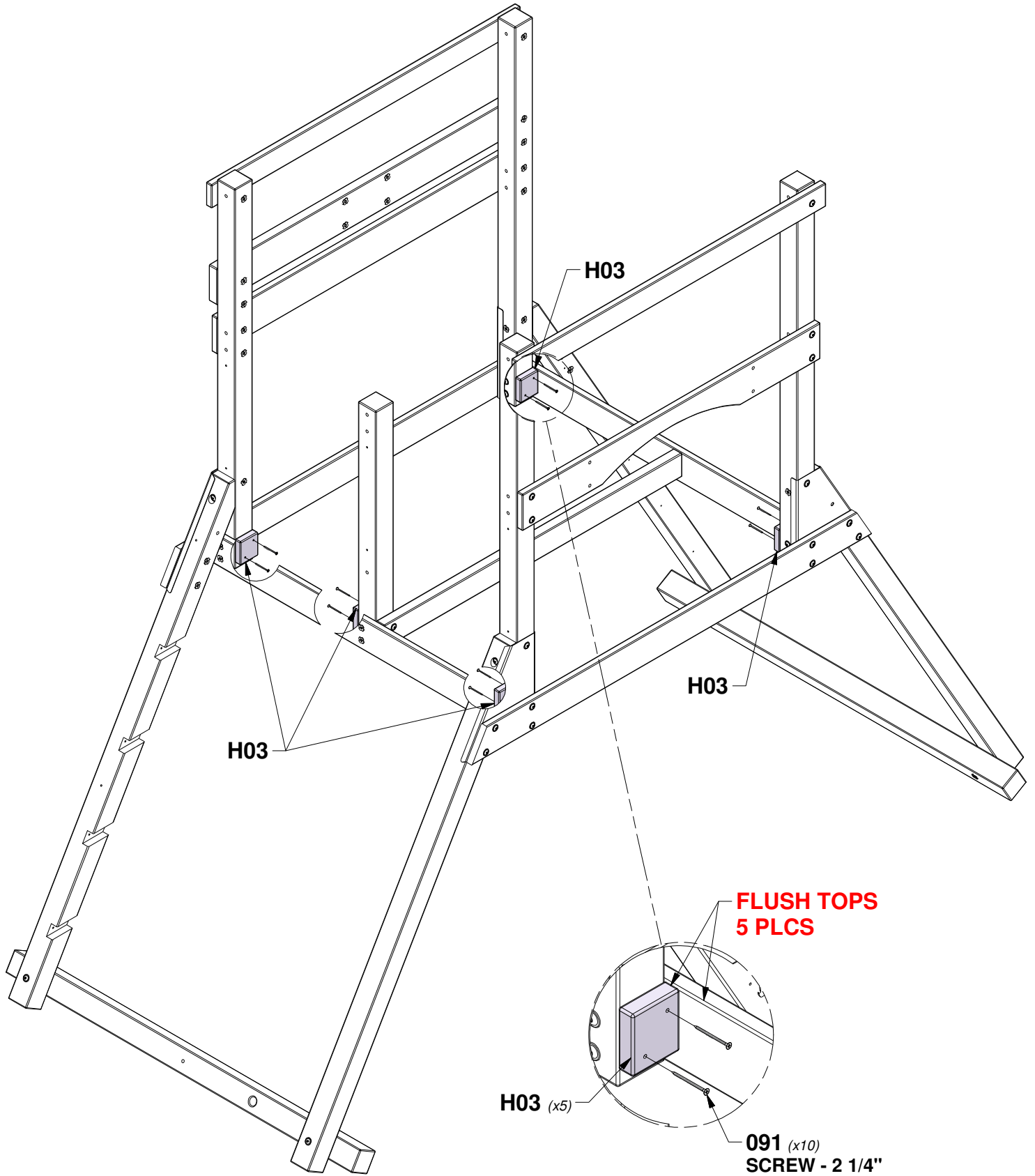

# STEP 12 - FORT ASSEMBLY

QTY	PART NUMBER	DESCRIPTION
1	H100022	BOLT WH 5/16x5
1	H100023	BOLT WH 5/16X6
2	H100030	WASHER LOCK EXT 8x19
2	H100074	T-NUT 5/16

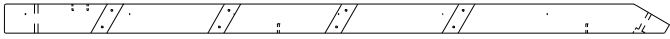

**B08** | LEG - W4L16433  
(x1) | 3"x3"x69 1/4" (76x76x1760)

**TIP:**  
**INSTALL T-NUTS IN WOOD FIRST**

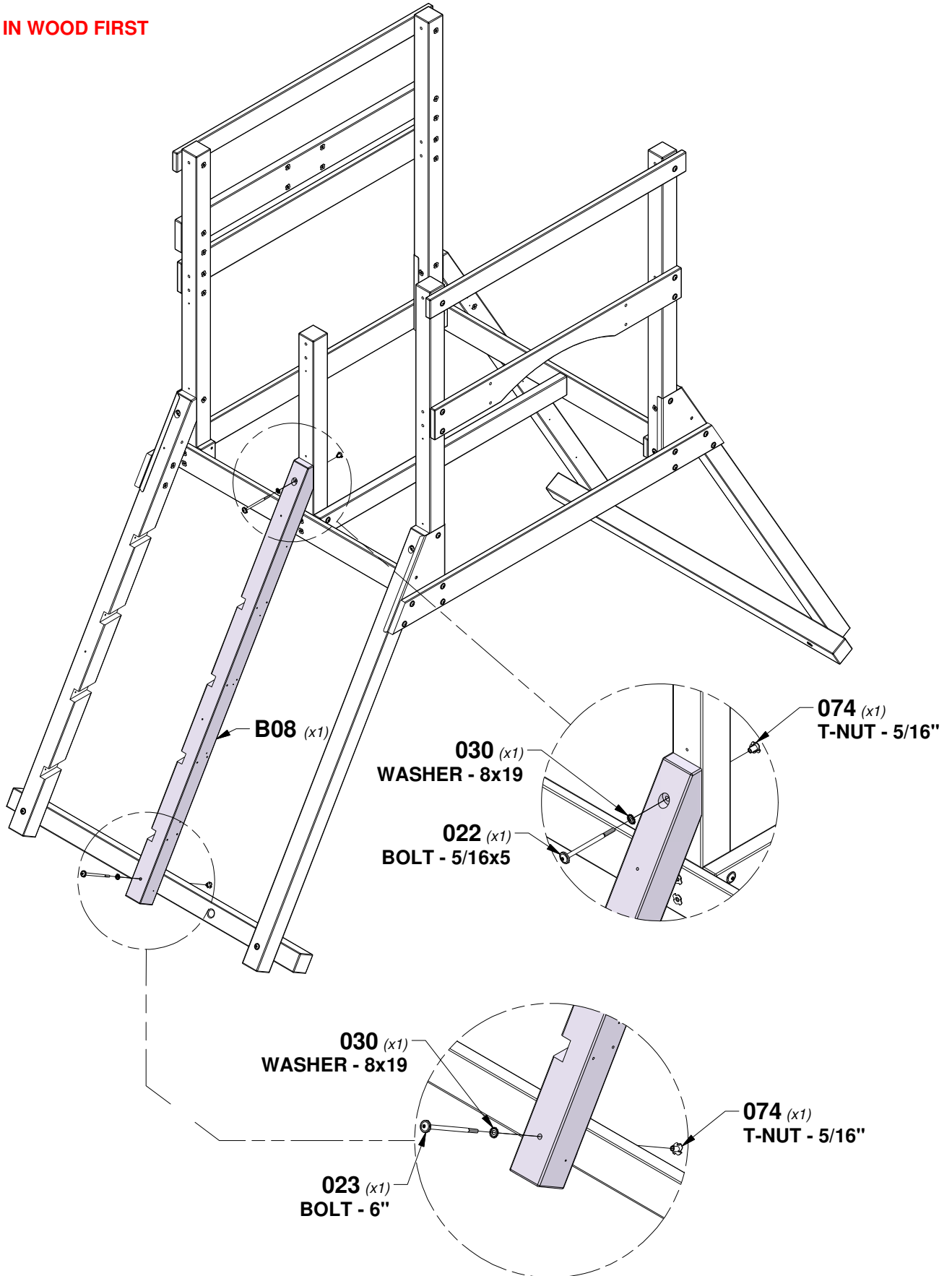

# STEP 13 - FORT ASSEMBLY

QTY	PART NUMBER	DESCRIPTION
16	H100092	SCREW PFH 8x3



**AL01** | STEP - W4L16431  
(x4) | 1 3/8"x4 3/8"x22 3/4" (36x112x579)

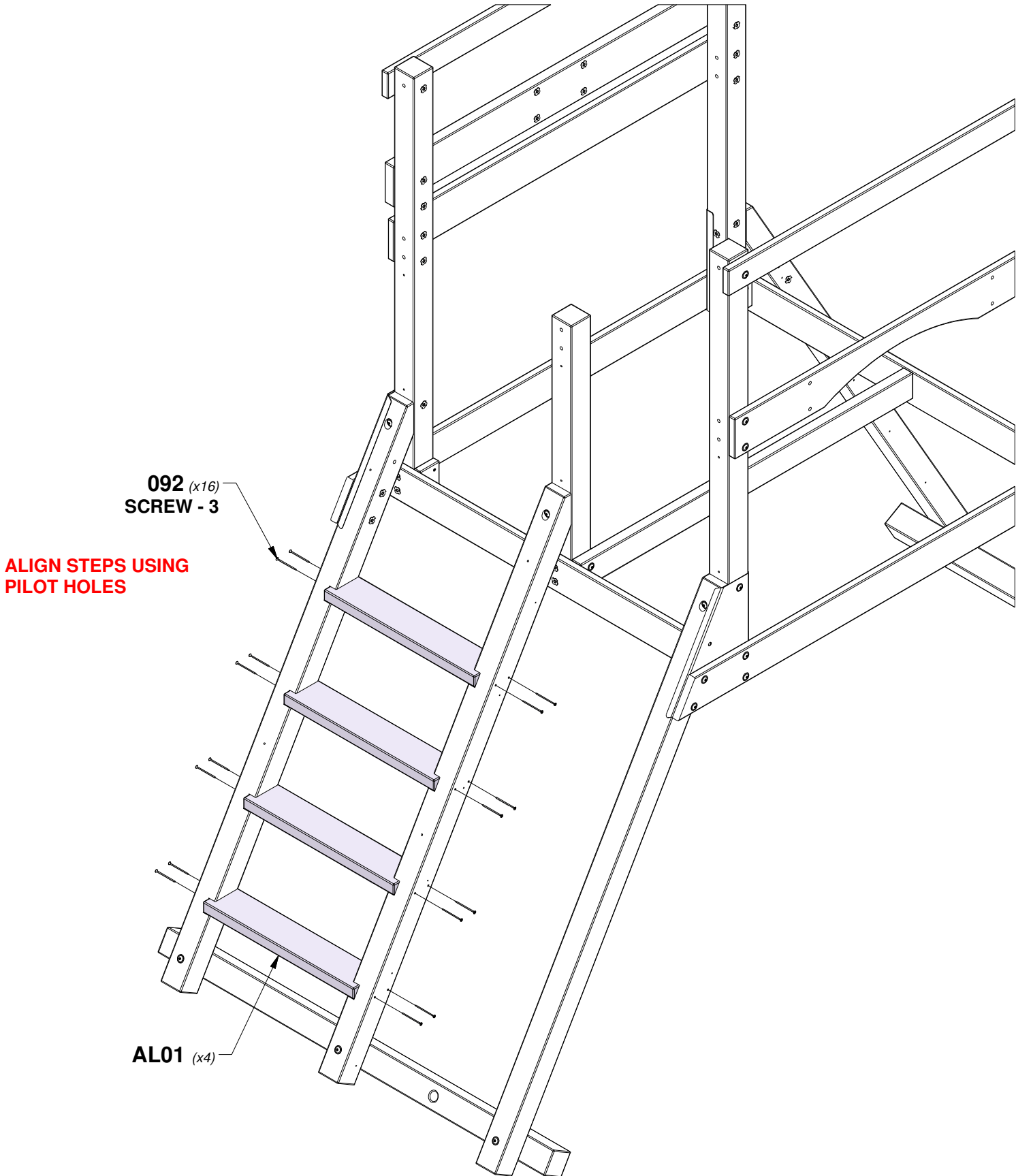

# STEP 14A - FORT ASSEMBLY

QTY	PART NUMBER	DESCRIPTION
3	H100089	SCREW PFH 8x1-3/4"
12	H100092	SCREW PFH 8x3

**T01** | CLEAT - W4L16442  
(x1) | 1"x1 3/8"x21 1/2" (24x34x546)

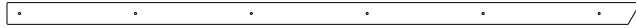

**F01** | CLEAT - W4L16440  
(x2) | 1 3/8"x2"x59 1/2" (36x52x1510)

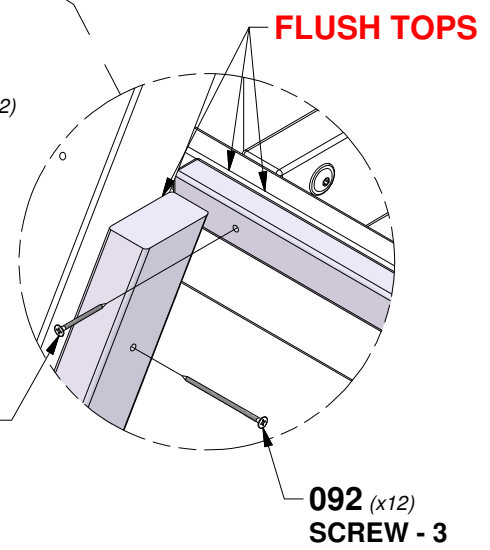
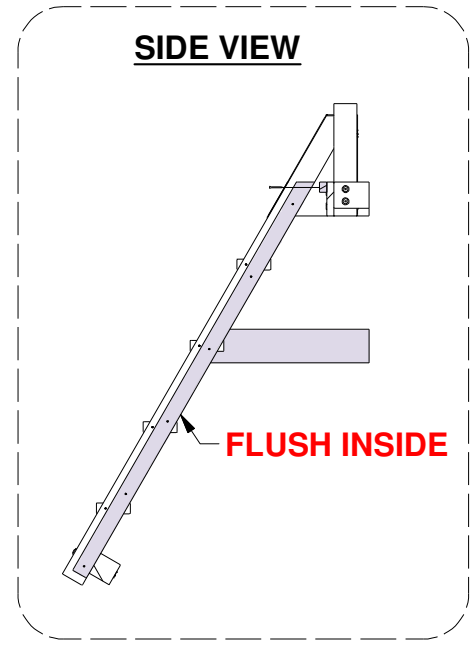
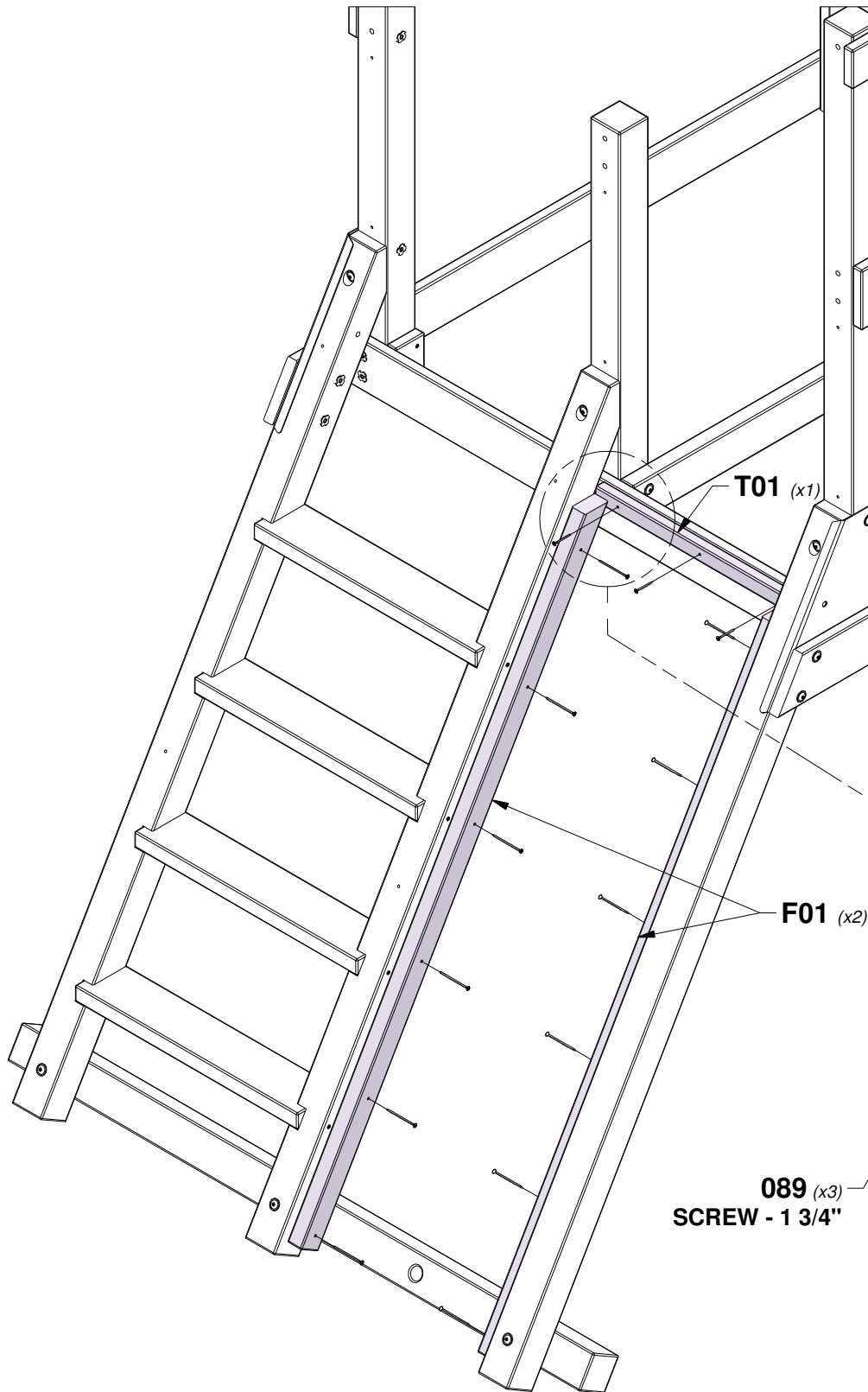

# STEP 14B - FORT ASSEMBLY

QTY	PART NUMBER	DESCRIPTION
4	H100027	LAG SCREW WH 5/16x2
4	H100030	WASHER LOCK EXT 8x19



**Q04 | SAFETY RAIL - W4L16475**  
 (x1) | 1"x4 3/8"x89 1/2" (24x112x2274)

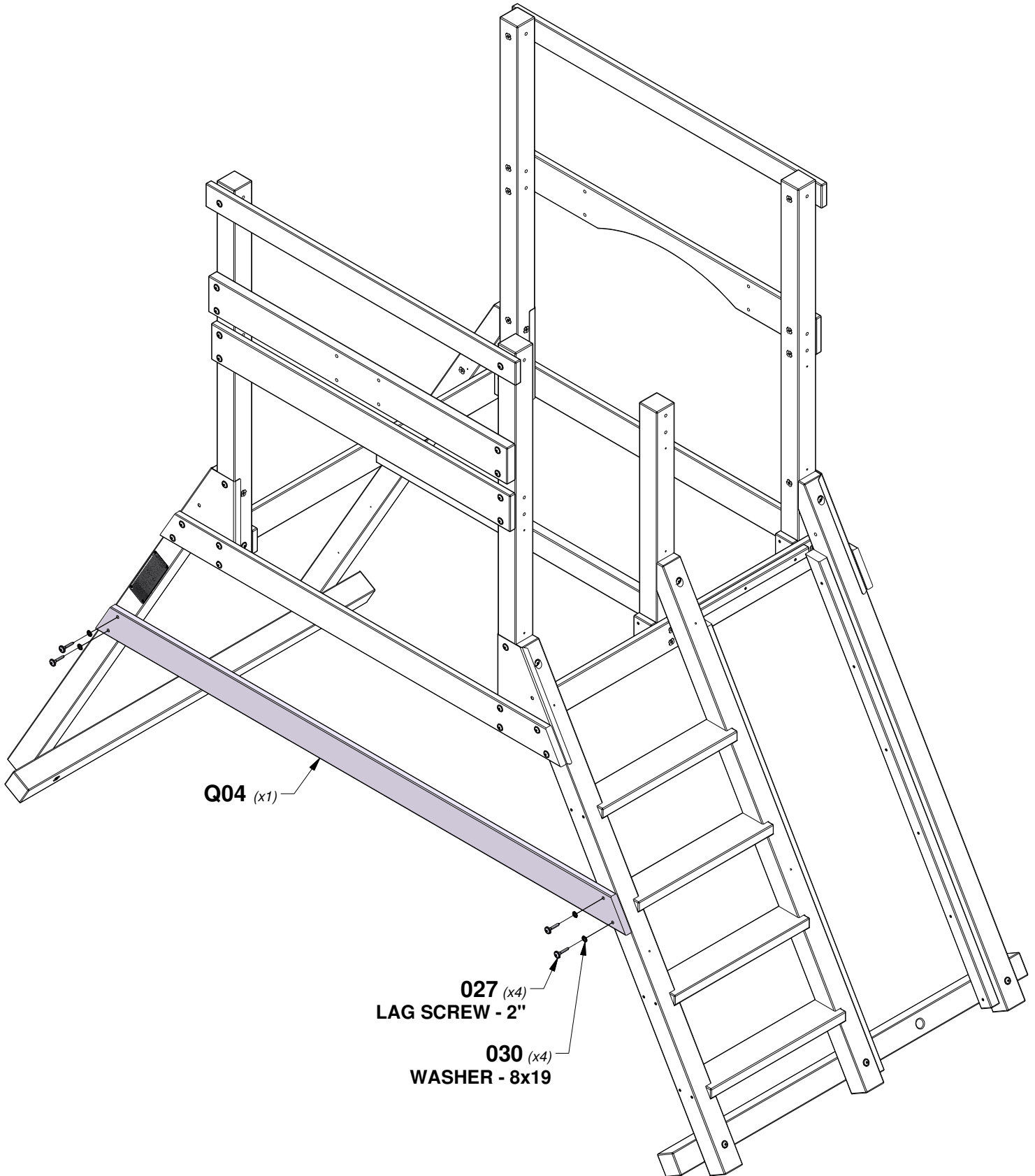

**Q04 (x1)**

**027 (x4)**  
 LAG SCREW - 2"

**030 (x4)**  
 WASHER - 8x19

# STEP 15 - FORT ASSEMBLY

QTY	PART NUMBER	DESCRIPTION
36	H100086	SCREW PFH 8x1-1/2"
32	H100111	SCREW PFH 8x2



**H04** ROPE WALL BOARD - W4L16438  
(x8) 1"x3 3/8"x20 7/8" (24x86x529)

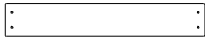

**M02** ROPE WALL BOARD - W4L16436  
(x8) 5/8"x3 3/8"x20 7/8" (16x86x529)

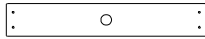

**M03** ROPE WALL BOARD - W4L16451  
(x1) 5/8"x3 3/8"x20 7/8" (16x86x529)

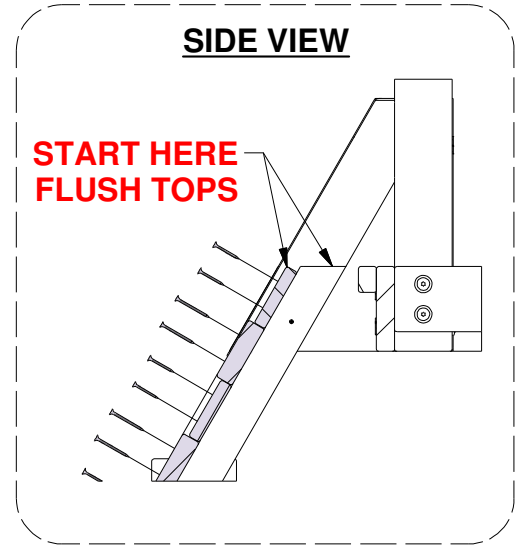
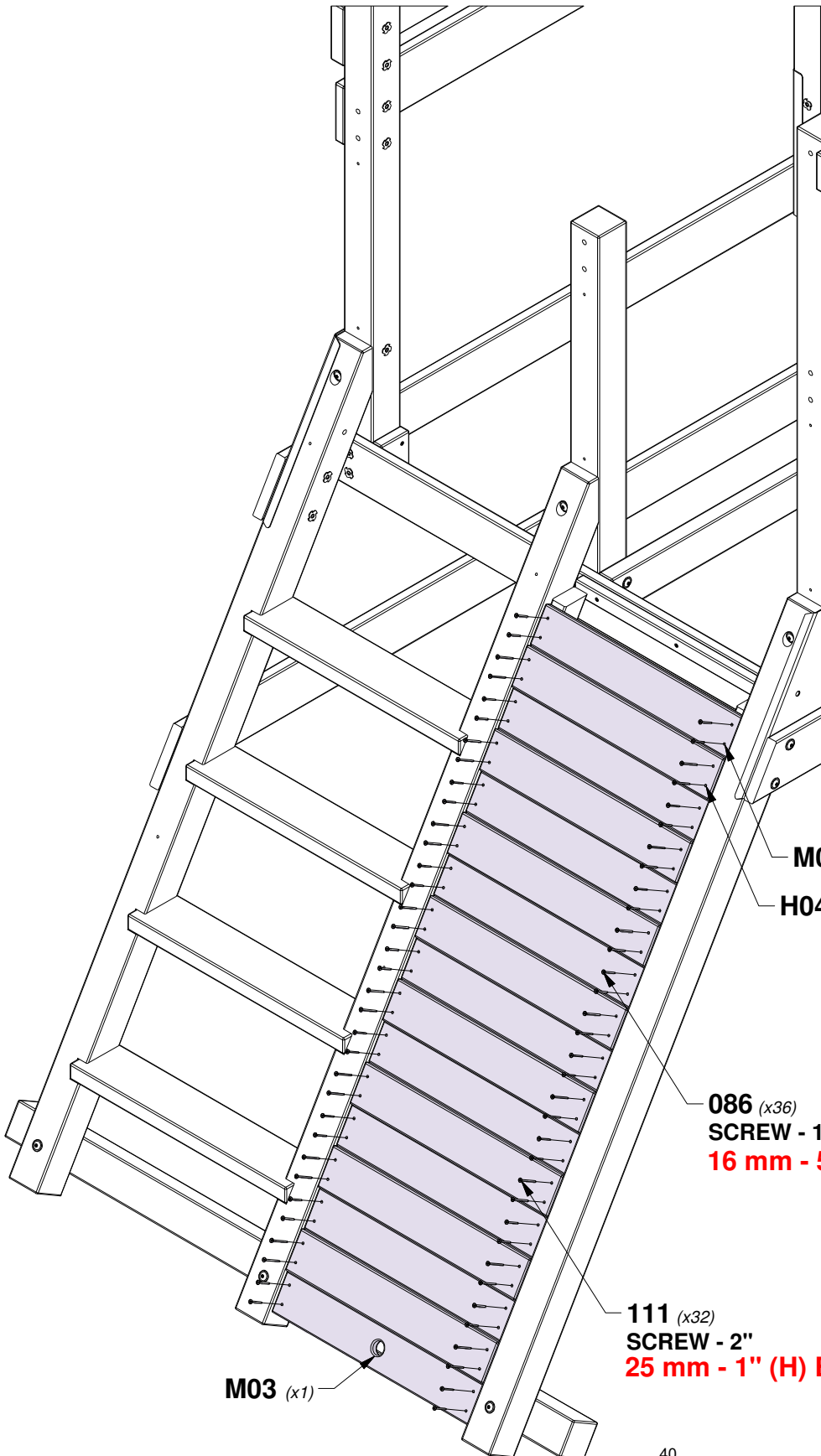

**M02 (x8)**  
**H04 (x8)** **ALTERNATE (M02) & (H04) PATTERN AS YOU GO DOWN**

**086 (x36)**  
**SCREW - 1 1/2"**  
**16 mm - 5/8" (M) BOARDS**

**111 (x32)**  
**SCREW - 2"**  
**25 mm - 1" (H) BOARDS**

**M03 (x1)**



# STEP 16 - FORT ASSEMBLY

QTY	PART NUMBER	DESCRIPTION
6	H100089	SCREW PFH 8x1-3/4"
12	H100092	SCREW PFH 8x3

**T01** | CLEAT - W4L16442  
(x2) | 1"x1 3/8"x21 1/2" (24x34x546)

**F01** | CLEAT - W4L16440  
(x2) | 1 3/8"x2"x59 1/2" (36x52x1510)

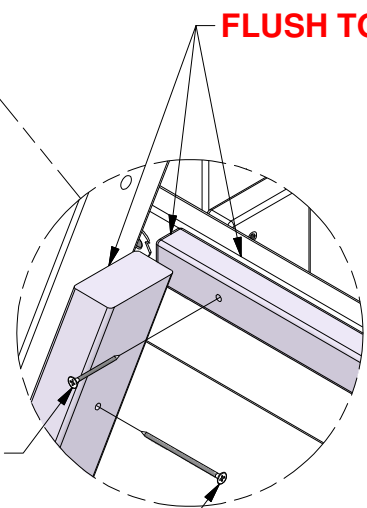
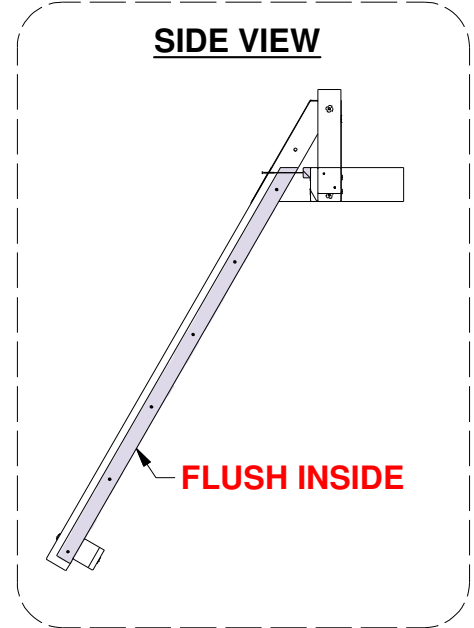
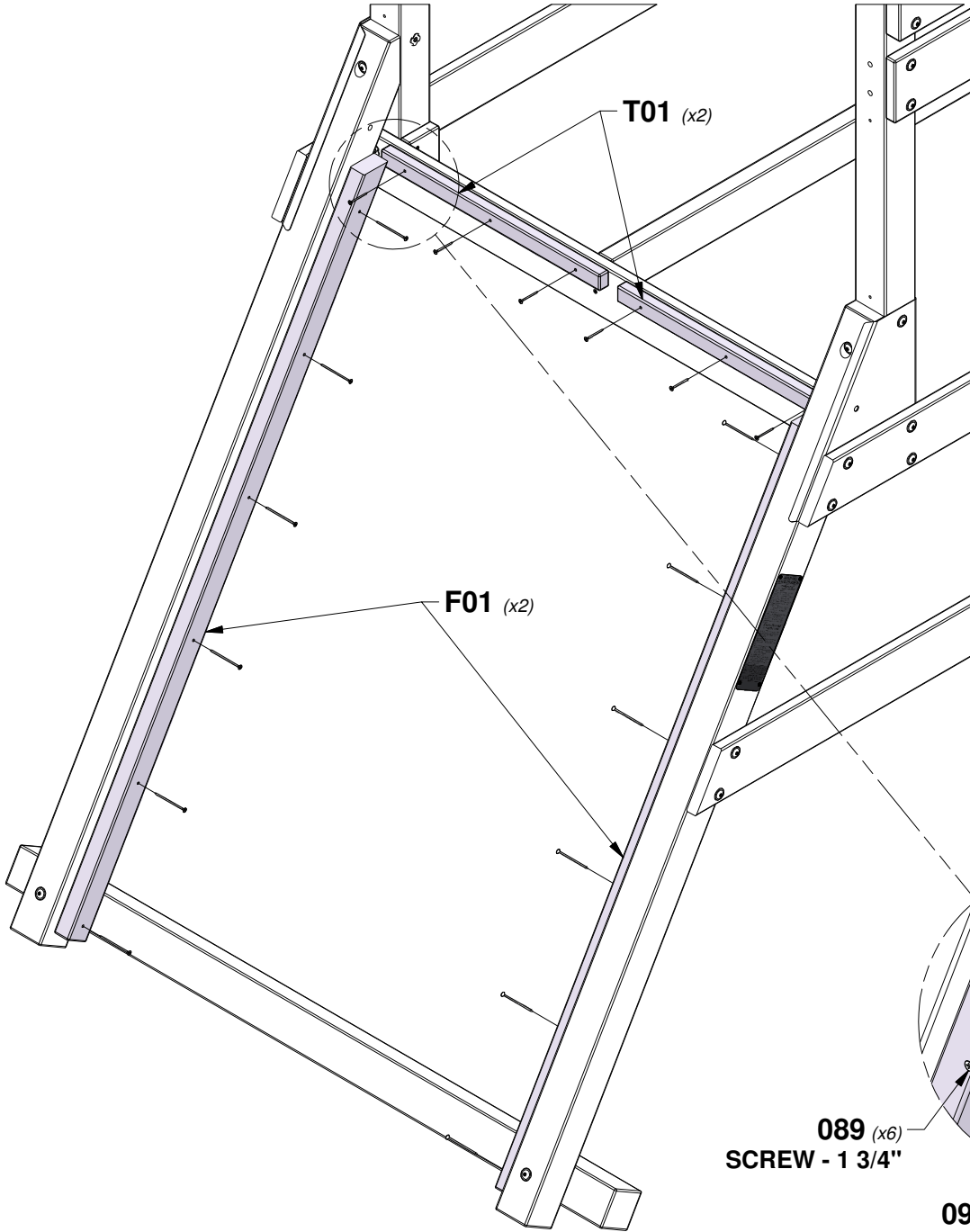

**089** (x6)  
SCREW - 1 3/4"

**092** (x12)  
SCREW - 3

# STEP 17A - FORT ASSEMBLY

QTY	PART NUMBER	DESCRIPTION
26	H100072	T-NUT 1/4
26	H100108	WASHER LOCK INT 8x15
26	H100137	BOLT WH 1/4x1

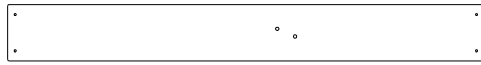

**G05 | ROCK WALL BOARD - W4L16444**  
(x5) | 1"x5 1/4"x44 5/8" (24x134x1135)



**G06 | ROCK WALL BOARD - W4L16445**  
(x4) | 1"x5 1/4"x44 5/8" (24x134x1135)

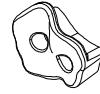

**A6P00037 | GREEN HC ROCK**  
(x6) | #2



**A6P00036 | GREEN HC ROCK**  
(x7) | #1

**TIP:**  
**INSTALL T-NUTS IN WOOD FIRST**

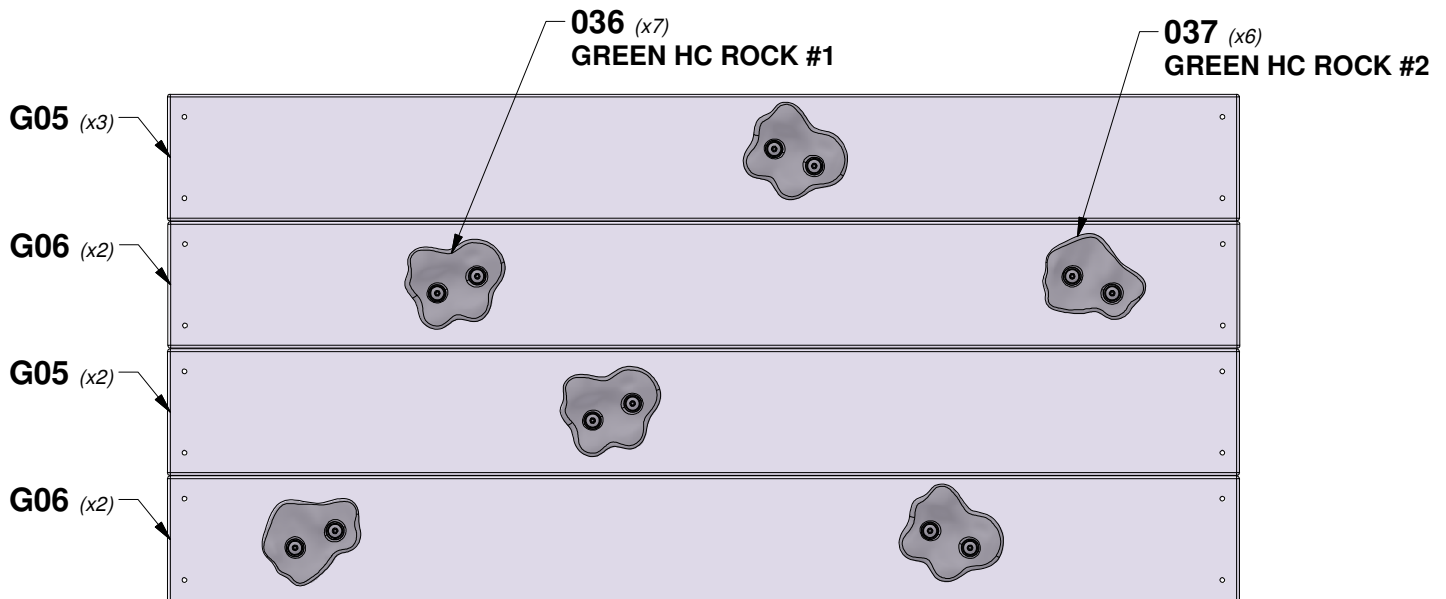
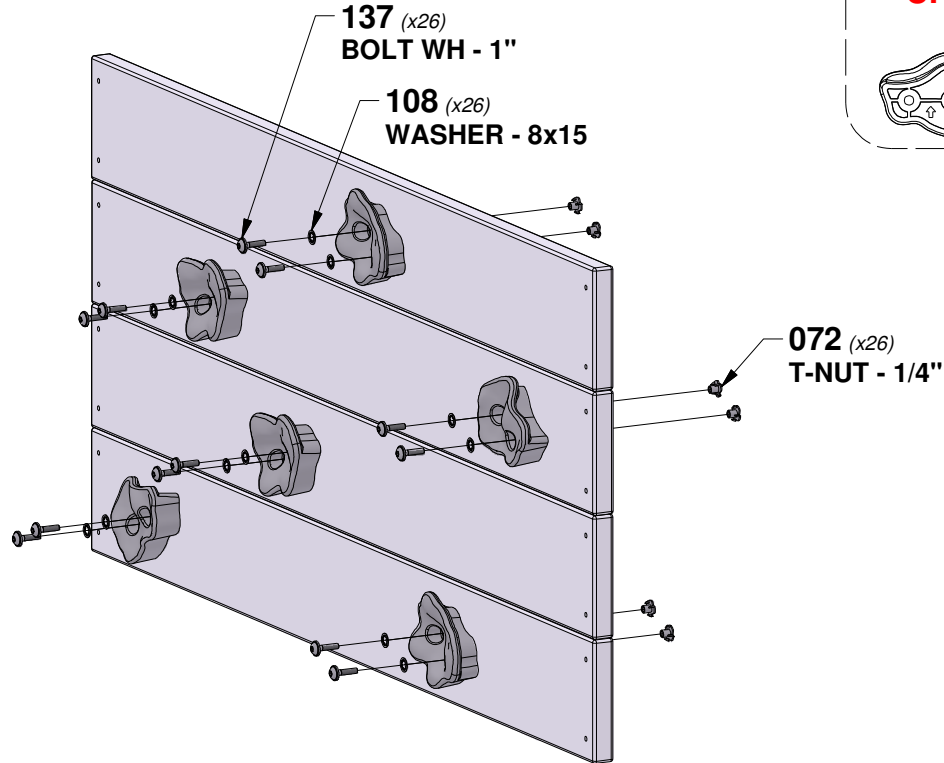
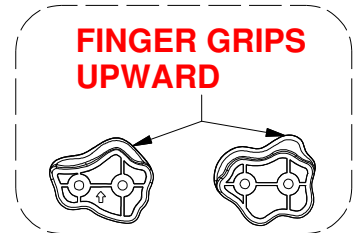

**PLACE ROCKS RANDOMLY**

# STEP 17B - FORT ASSEMBLY

QTY	PART NUMBER	DESCRIPTION
44	H100111	SCREW PFH 8x2"



**G01** | ROCK WALL BOARD - W4L16452  
(x2) | 1"x5 1/4"x44 5/8" (24x134x1135)

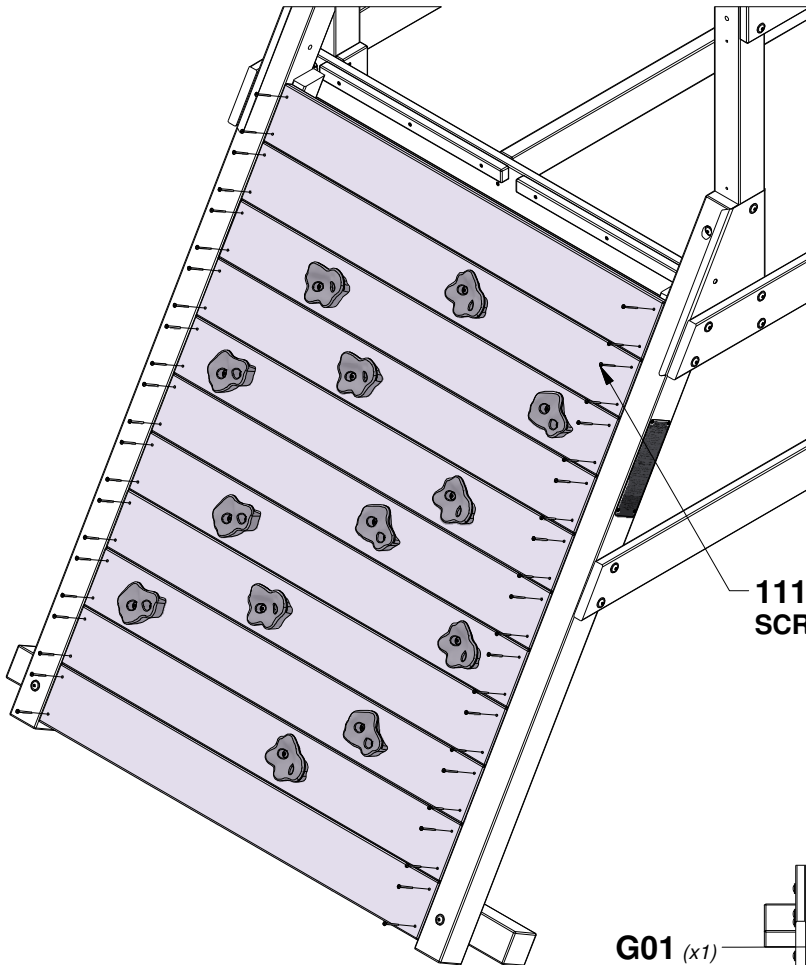
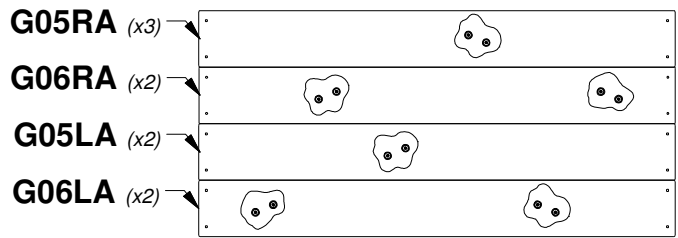

**111** (x44)  
SCREW - 2"

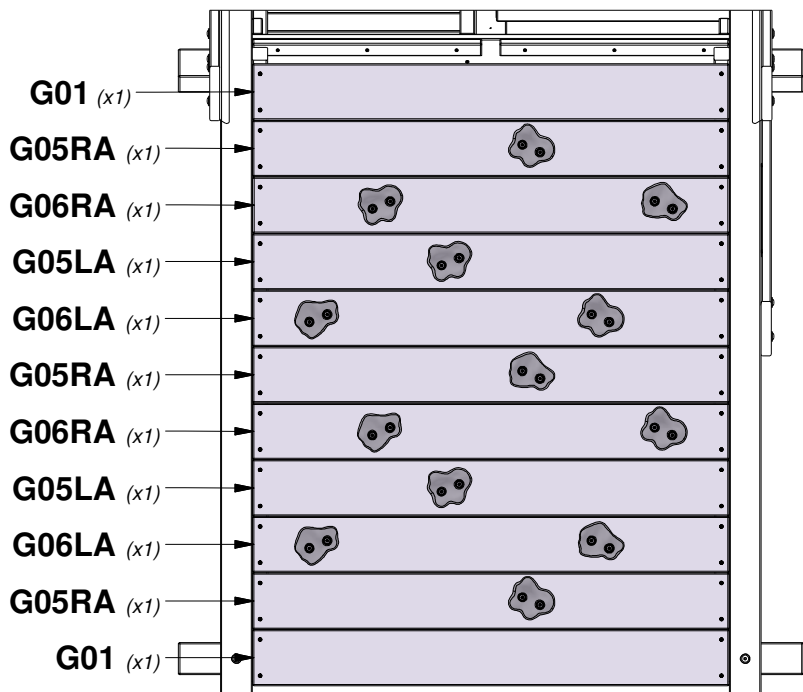
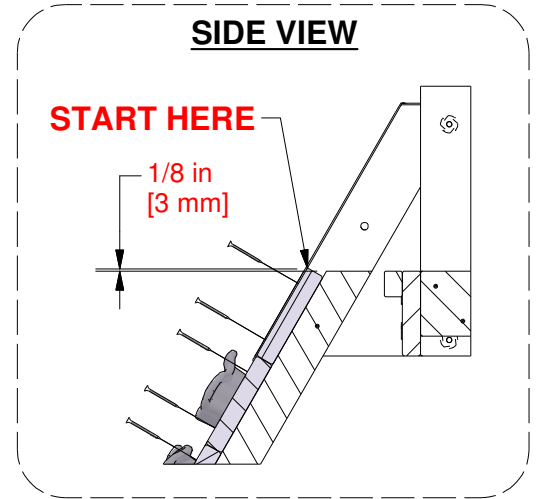

# STEP 18 - FORT ASSEMBLY

QTY	PART NUMBER	DESCRIPTION
20	H100086	SCREW PFH 8x1-1/2"

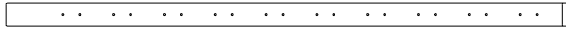

**J01** | ROCK WALL CLEAT - W4L16447  
 (x1) 1"x2 3/8"x58 1/2" (24x60x1486)

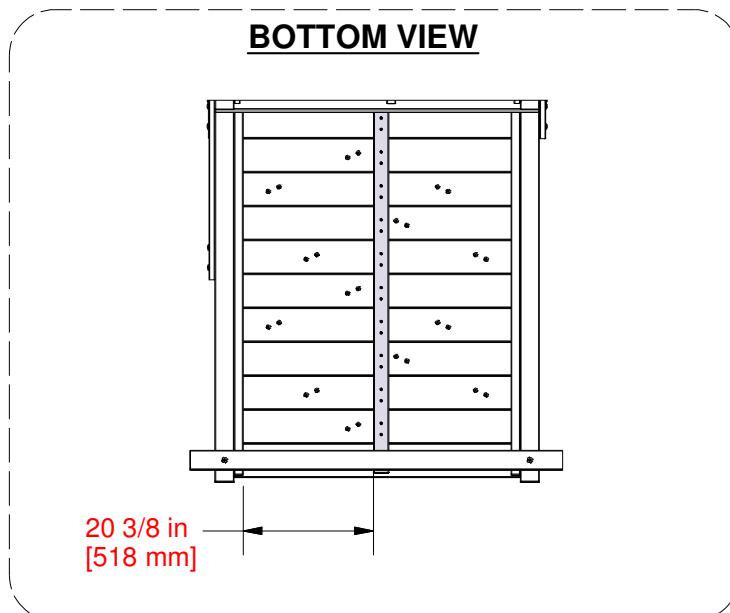
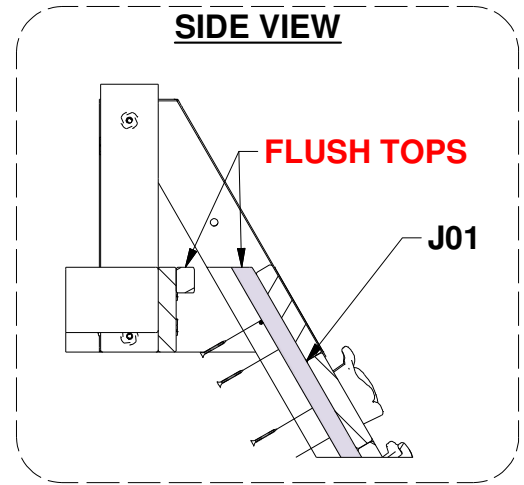
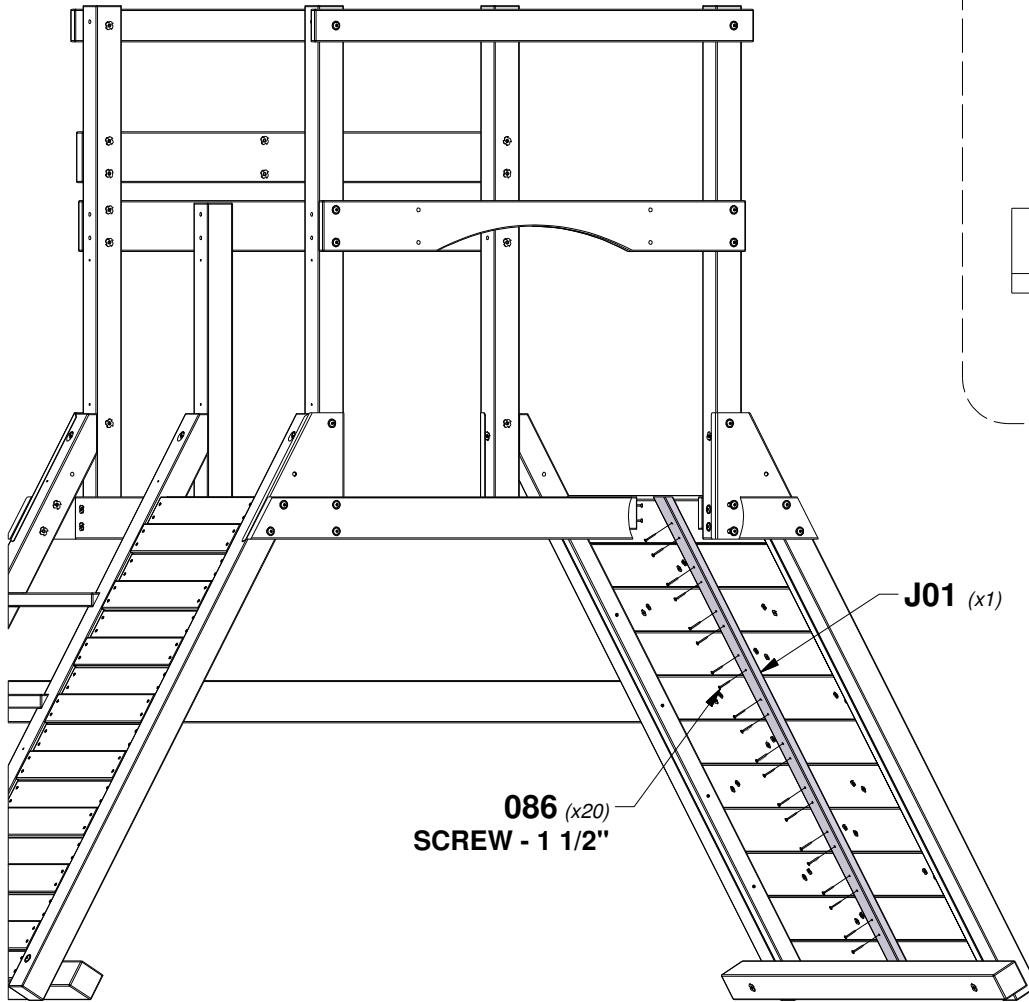

# STEP 19 - FORT ASSEMBLY

QTY	PART NUMBER	DESCRIPTION
78	H100086	SCREW PFH 8x1-1/2"

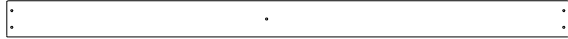

**M01 | FLOOR BOARD - W4L16437**  
(x13) 5/8"x3 3/8"x52 3/4" (16x86x1339)



**Y01 | FLOOR BOARD - W4L16432**  
(x2) 5/8"x4"x20 7/8" (16x102x529)



**Y02 | FLOOR BOARD - W4L16439**  
(x1) 5/8"x4"x44 5/8" (16x102x1135)

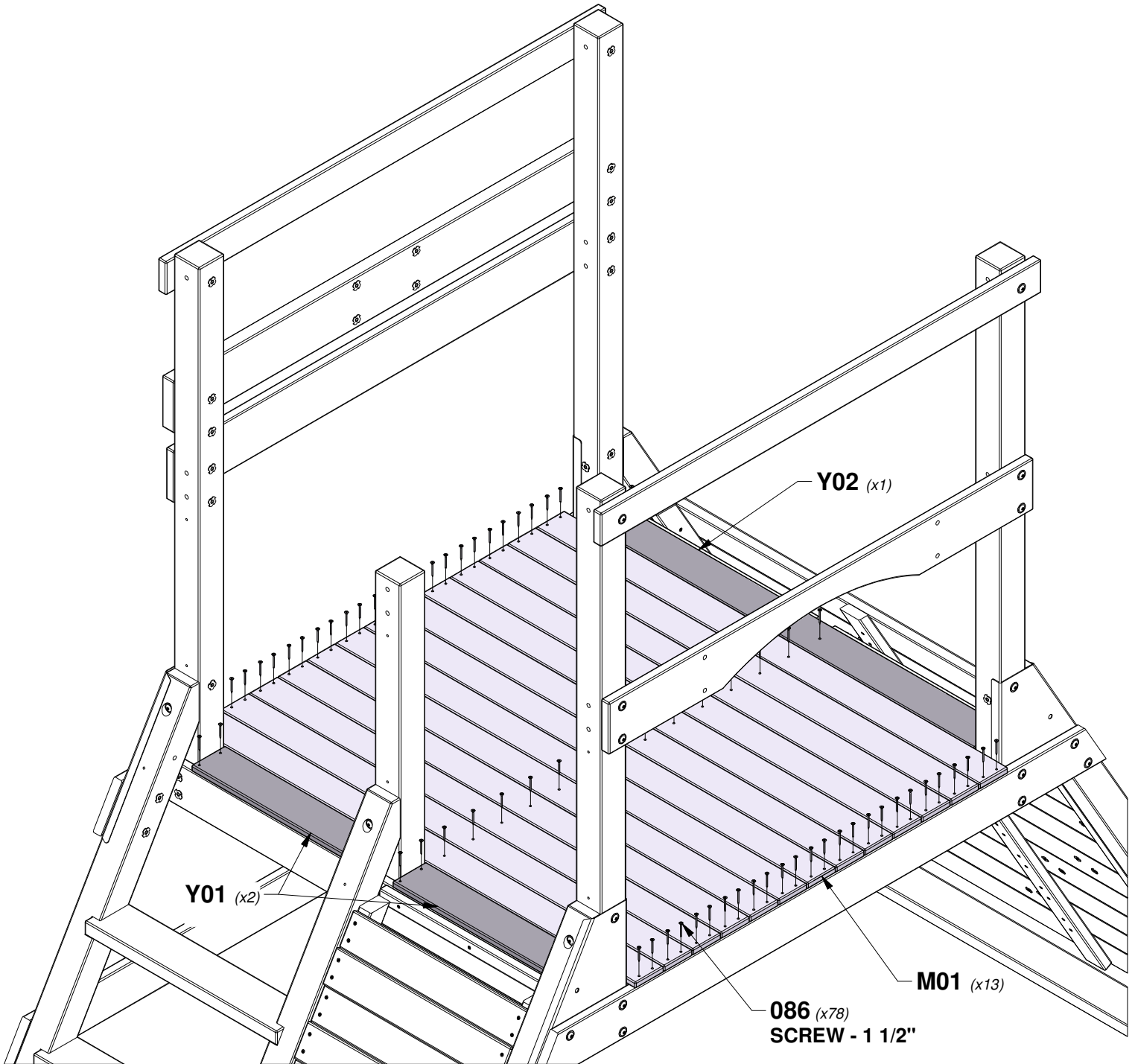

# STEP 20 - FORT ASSEMBLY

QTY	PART NUMBER	DESCRIPTION
11	H100086	SCREW PFH 8x1-1/2"

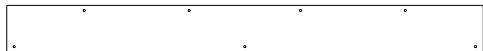

**K04 | FLOOR BOARD - W4L16448**  
 (x1) | 5/8"x4 3/4"x44 5/8" (16x120x1135)



**K05 | FLOOR BOARD - W4L16449**  
 (x1) | 5/8"x4 3/4"x20 7/8" (16x120x529)

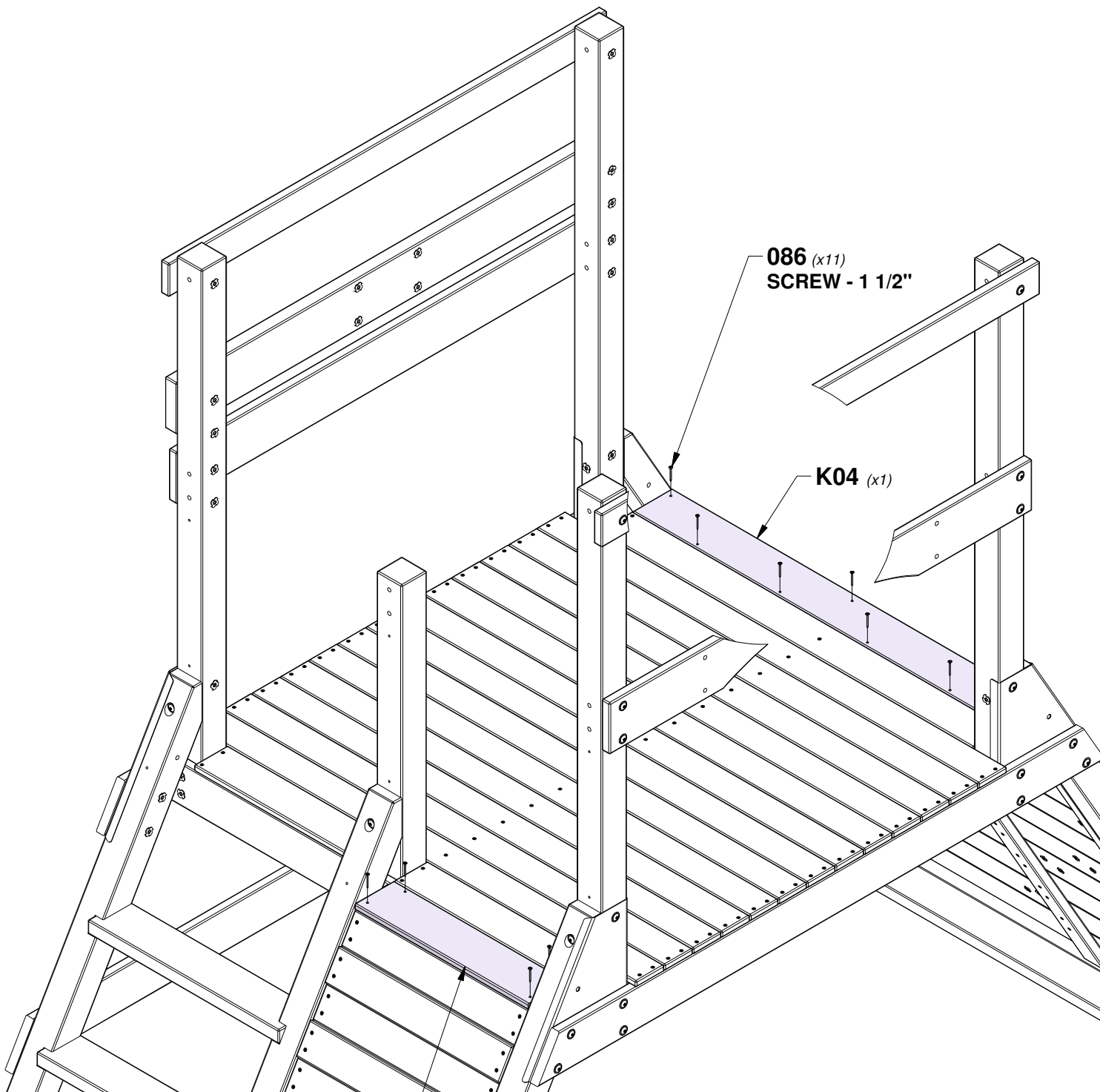

**K05 (x1)**

# STEP 21 - FORT ASSEMBLY

QTY	PART NUMBER	DESCRIPTION
4	H100019	BOLT WH 5/16x3 3/4
4	H100030	WASHER LOCK EXT 8x19
4	H100074	T-NUT 5/16



**H01** | FLOOR RAIL - W4L16428  
(x1) | 1"x3 3/8"x61 3/4" (24x86x1569)

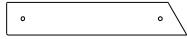

**H02** | FLOOR RAIL - W4L16429  
(x2) | 1"x3 3/8"x18 3/4" (24x86x477)

**TIP:**  
INSTALL T-NUTS IN WOOD FIRST

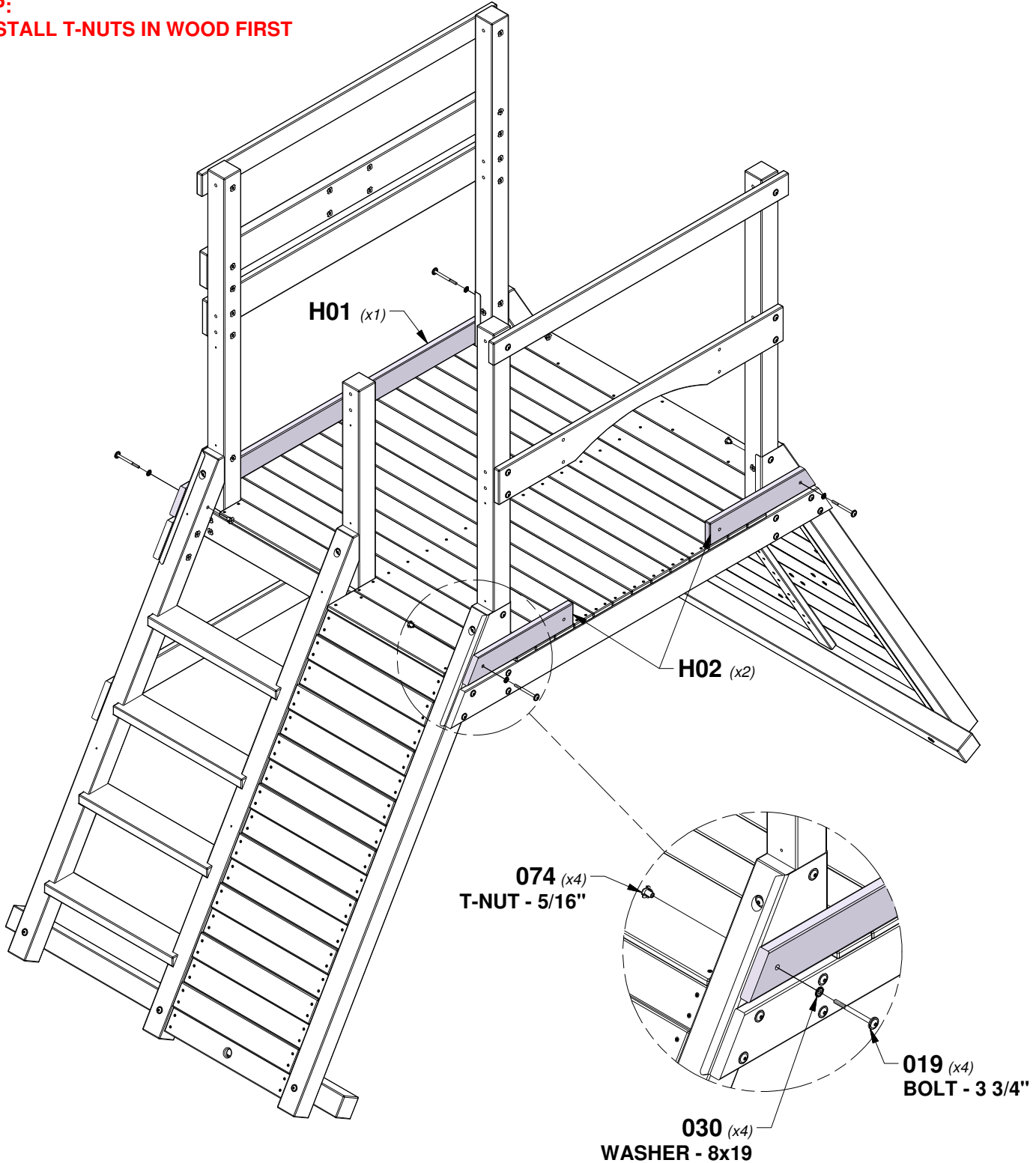

# STEP 22 - FORT ASSEMBLY



**H05** | WALL RAIL - W4L16450  
(x2) | 1"x3 3/8"x29 7/8" (24x86x760)



**A4M01047** | L BRACKET  
(x2) | 2.5x38x55x55

QTY	PART NUMBER	DESCRIPTION
2	H100005	NUT BARREL WH 5/16x7/8
4	H100011	BOLT WH 5/16x1 3/4
4	H100030	WASHER LOCK EXT 8x19
2	H100031	WASHER LOCK EXT 12x19
4	H100074	T-NUT 5/16
2	H100379	T-NUT 5/16 BLK
2	H100396	BOLT WH 5/16x1/2 BLK
2	H100407	BOLT WH 5/16x1 1/2 BLK

**TIP:**  
INSTALL T-NUTS IN WOOD FIRST

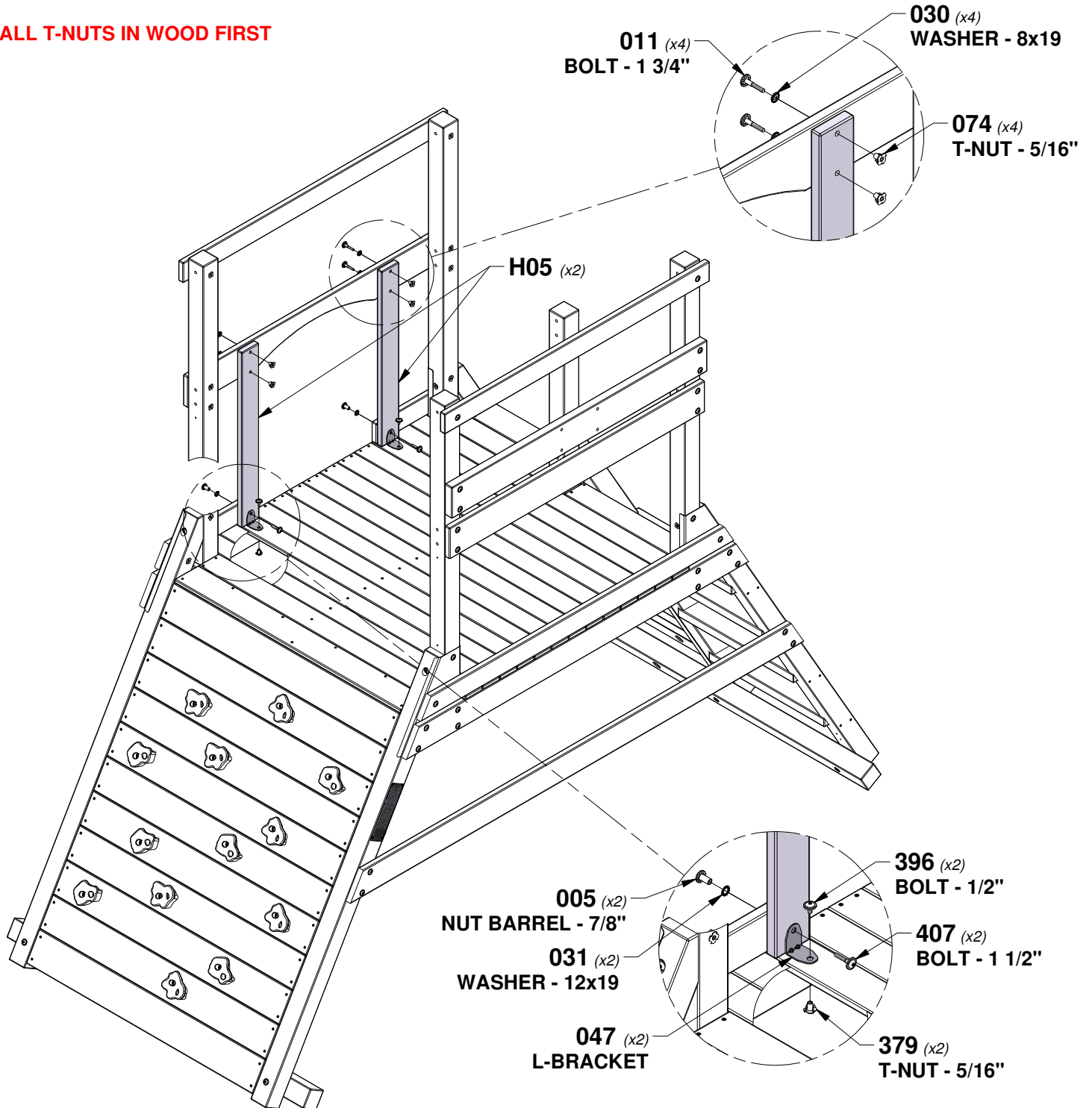

**USING BRACKETS AS A GUIDE, DRILL (2) 3/8" (10mm) HOLES THRU FLOOR FOR HARDWARE.**



# STEP 23 - FORT ASSEMBLY

QTY	PART NUMBER	DESCRIPTION
4	H100019	BOLT WH 5/16x3 3/4
4	H100030	WASHER LOCK EXT 8x19
4	H100074	T-NUT 5/16

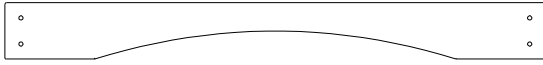

**G03** | WALL RAIL - W4L16424  
(x1) 1"x5 1/4"x50 3/4" (24x134x1288)

**TIP:**  
INSTALL T-NUTS IN WOOD FIRST

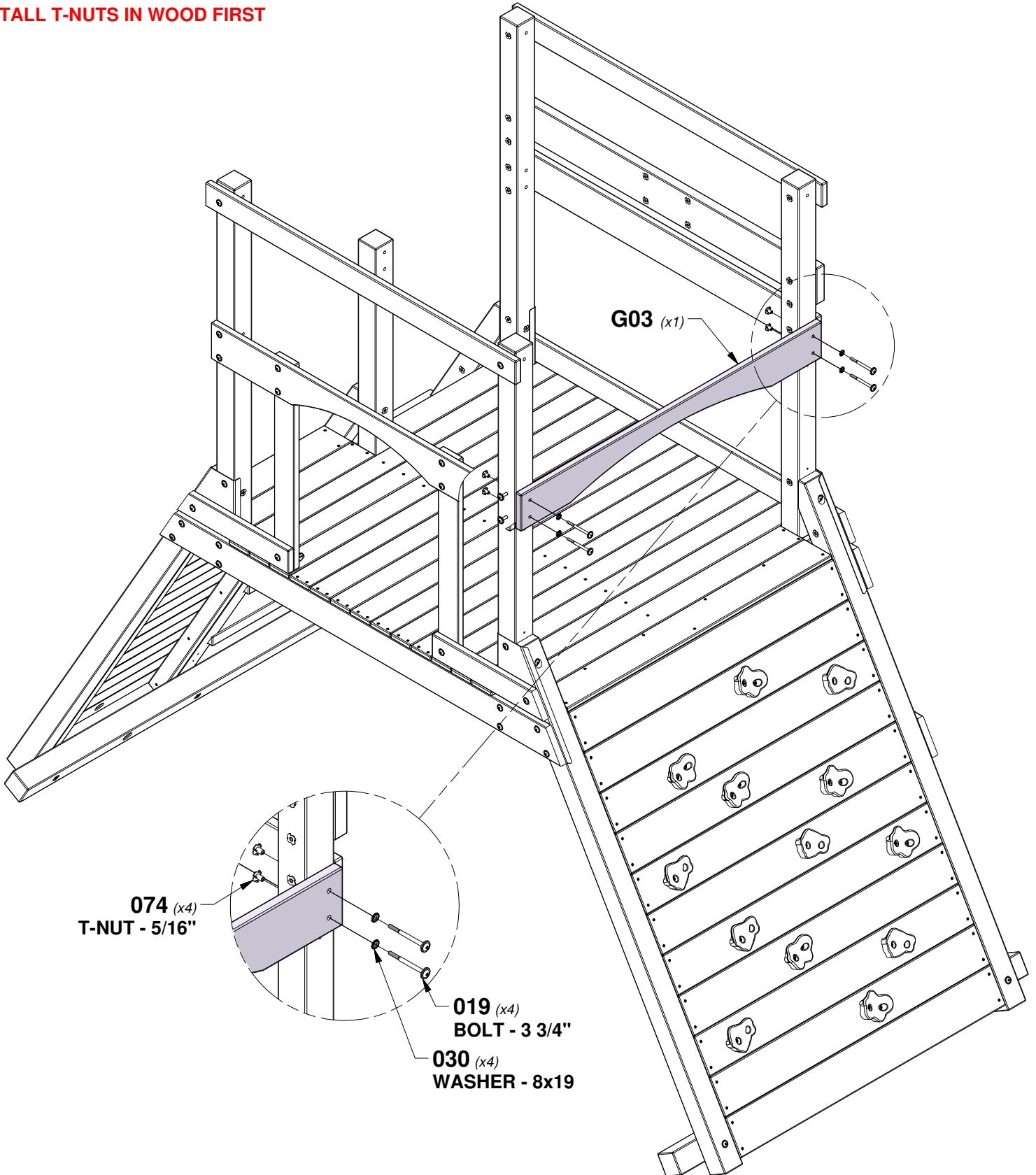

**074** (x4)  
T-NUT - 5/16"

**019** (x4)  
BOLT - 3 3/4"

**030** (x4)  
WASHER - 8x19

# STEP 24 - FORT ASSEMBLY

QTY	PART NUMBER	DESCRIPTION
6	H100030	WASHER LOCK EXT 8x19
6	H100074	T-NUT 5/16
6	H100166	BOLT WH 5/16x4 1/4

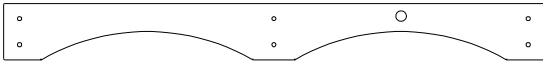

**D02 | WALL RAIL - W4L16422**  
 (x1) | 1 3/8"x5 1/4"x50 3/4" (36x134x1288)

**TIP:**  
**INSTALL T-NUTS IN WOOD FIRST**

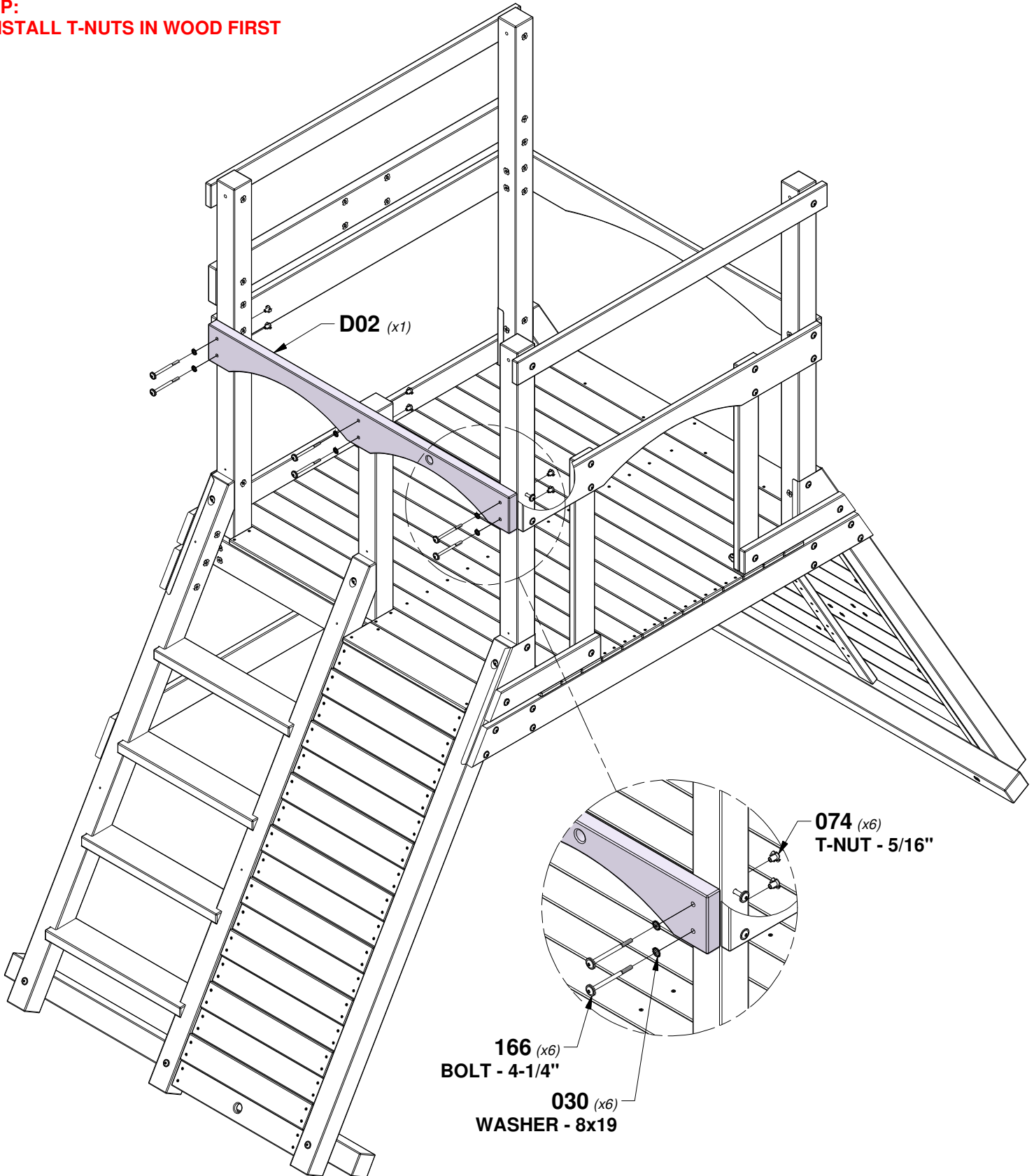

# STEP 25 - FORT ASSEMBLY

QTY	PART NUMBER	DESCRIPTION
4	H100086	SCREW PFH 8x1-1/2"



**M05** | SAFETY BOARD - W4L16467  
 (x1) | 5/8"x3 3/8"x26 7/8" (16x86x682)

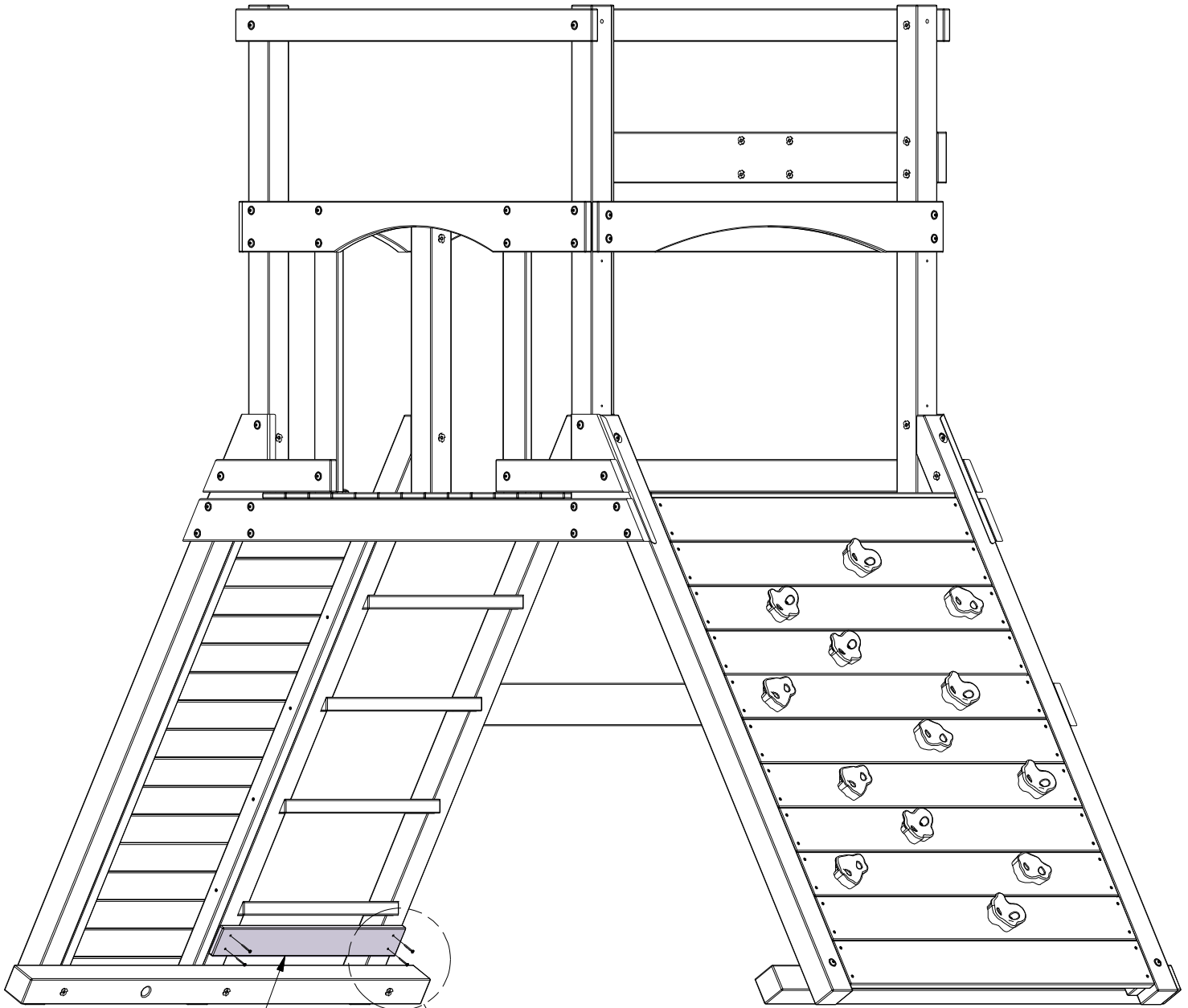

**M05** (x1)

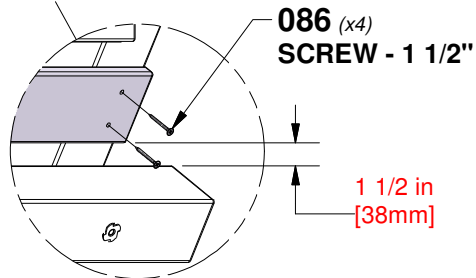

# STEP 26 - FORT ASSEMBLY

QTY	PART NUMBER	DESCRIPTION
8	H100086	SCREW PFH 8x1-1/2"

**M04** PICKET - W4L16466  
(x2) 5/8"x3 3/8"x29 7/8" (16x86x760)

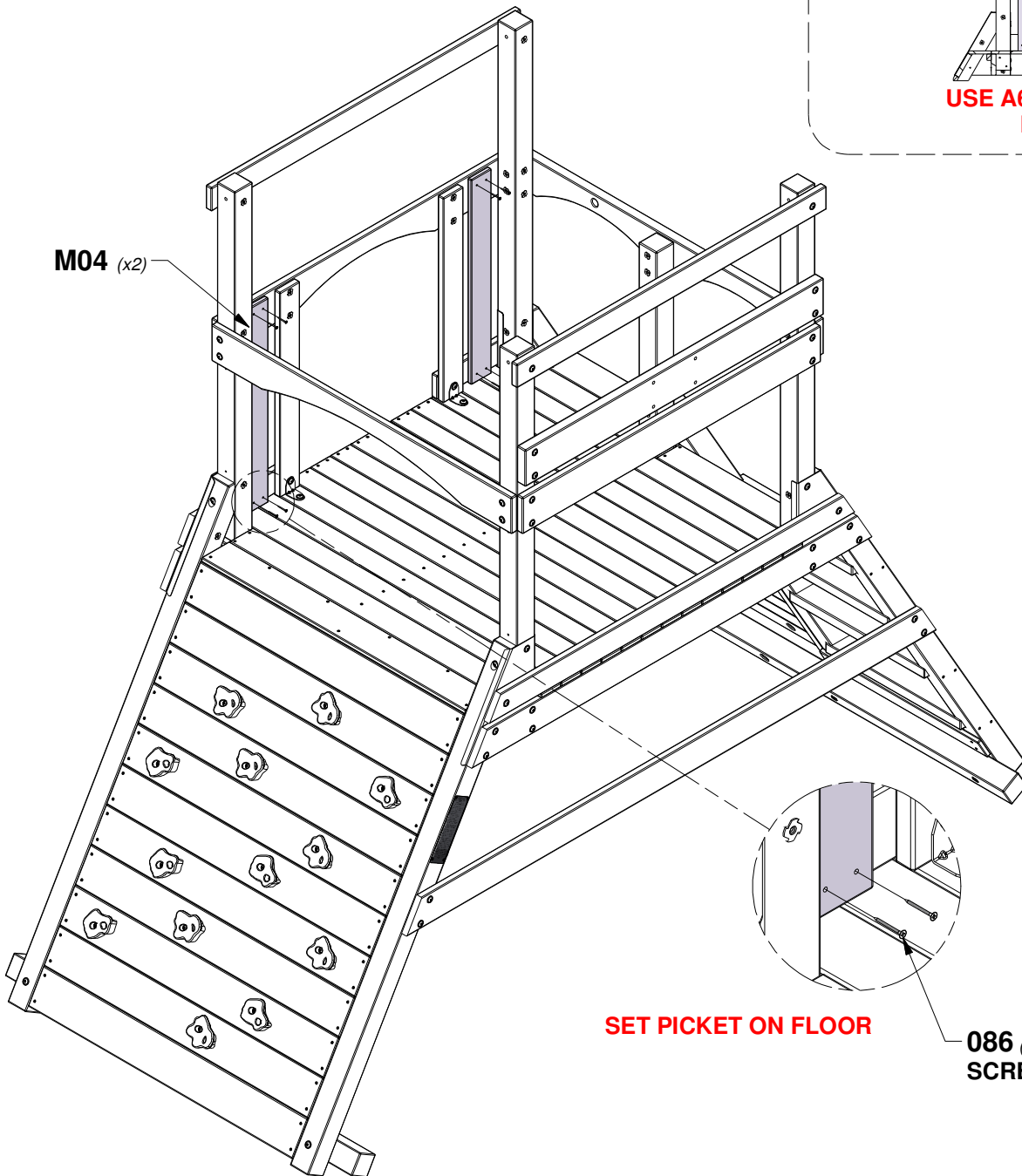
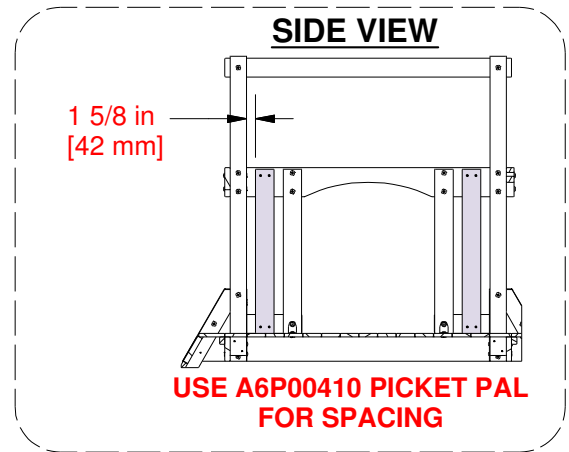

# STEP 27 - FORT ASSEMBLY

QTY	PART NUMBER	DESCRIPTION
28	H100086	SCREW PFH 8x1-1/2"



**M04** PICKET - W4L16466  
 (x7) 5/8"x3 3/8"x29 7/8" (16x86x760)

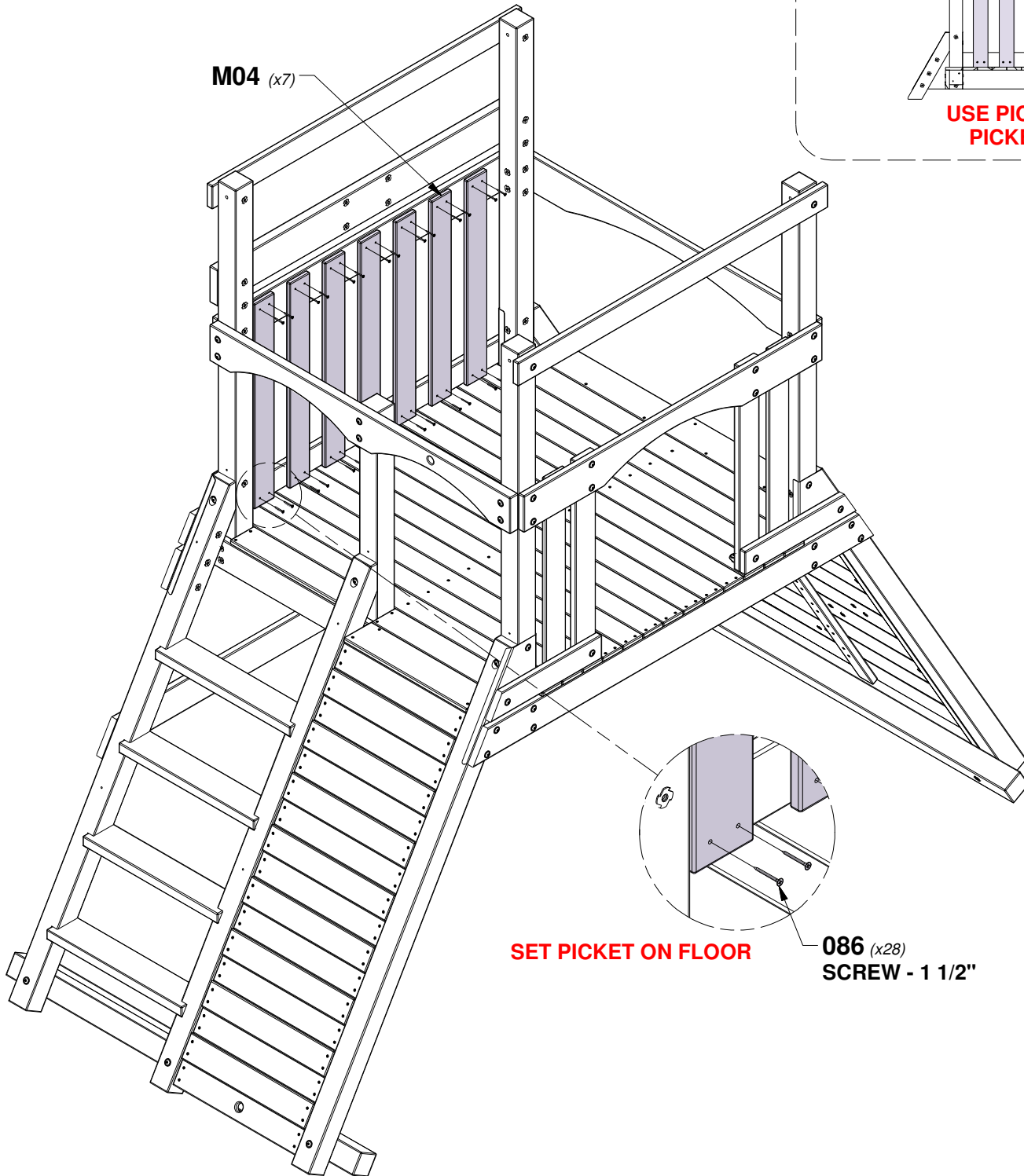
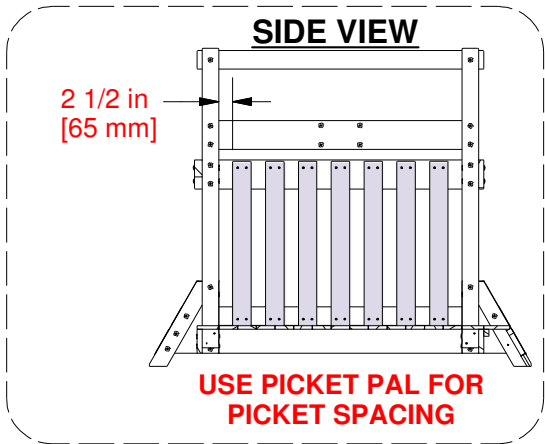

# STEP 28 - FORT ASSEMBLY

QTY	PART NUMBER	DESCRIPTION
4	H100030	WASHER LOCK EXT 8x19
4	H100074	T-NUT 5/16
4	H100505	BOLT WH 5/16x4 3/4

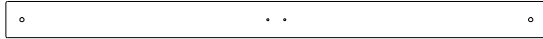

**H07** | WALL RAIL - W4L16453  
(x2) | 1"x3 3/8"x50 3/4" (24x86x1288)



**H09** | ROOF RAIL - W4L16455  
(x4) | 1"x3 3/8"x34 1/2" (24x86x877)

**TIP:**  
INSTALL T-NUTS IN WOOD FIRST

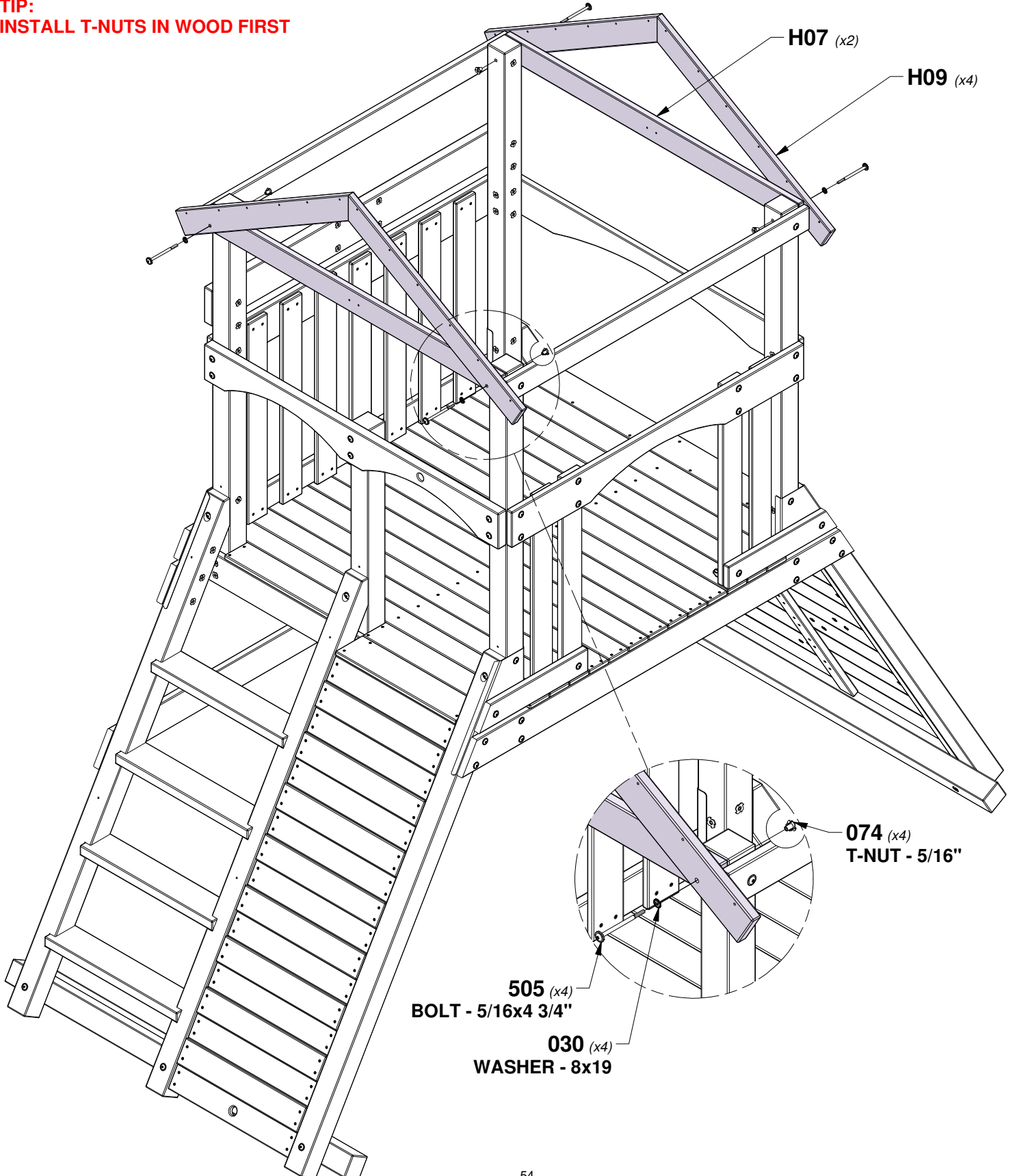

**H07** (x2)

**H09** (x4)

**074** (x4)  
T-NUT - 5/16"

**505** (x4)  
BOLT - 5/16x4 3/4"

**030** (x4)  
WASHER - 8x19

# STEP 29 - FORT ASSEMBLY

QTY	PART NUMBER	DESCRIPTION
12	H100089	SCREW PFH 8x1-3/4"



**H10 | GABLE BOARD - W4L16456**  
(x2) | 1"x3 3/8"x15 3/4" (24x86x400)



**H11 | GABLE CLEAT - W4L16457**  
(x2) | 1"x3"x3 3/8" (24x76x86)

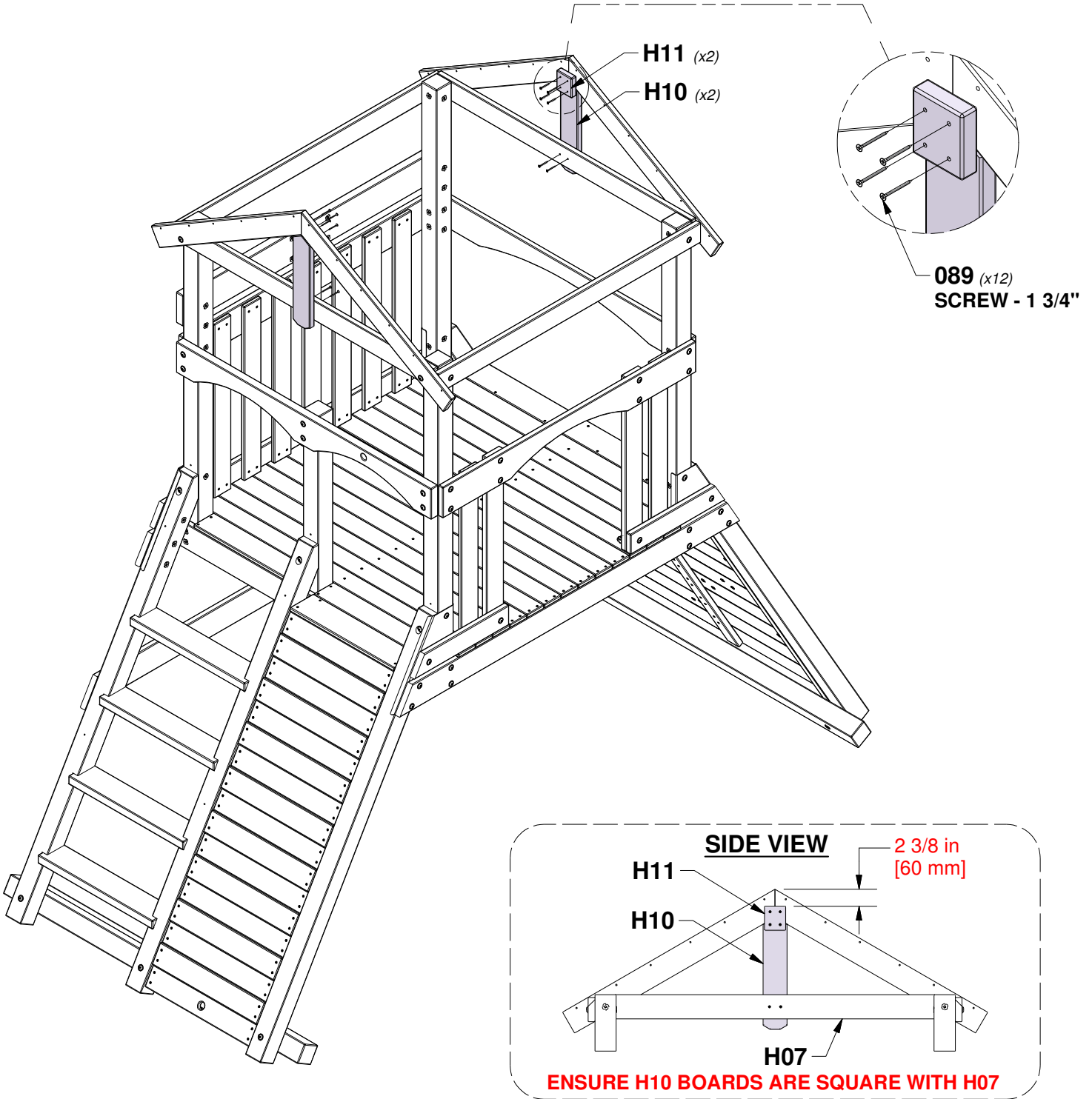

# STEP 30 - FORT ASSEMBLY

QTY	PART NUMBER	DESCRIPTION
12	H100089	SCREW PFH 8x1-3/4"



**H12** GABLE BOARD - W4L16458  
(x4) 1"x3 3/8"x14 5/8" (24x86x370)

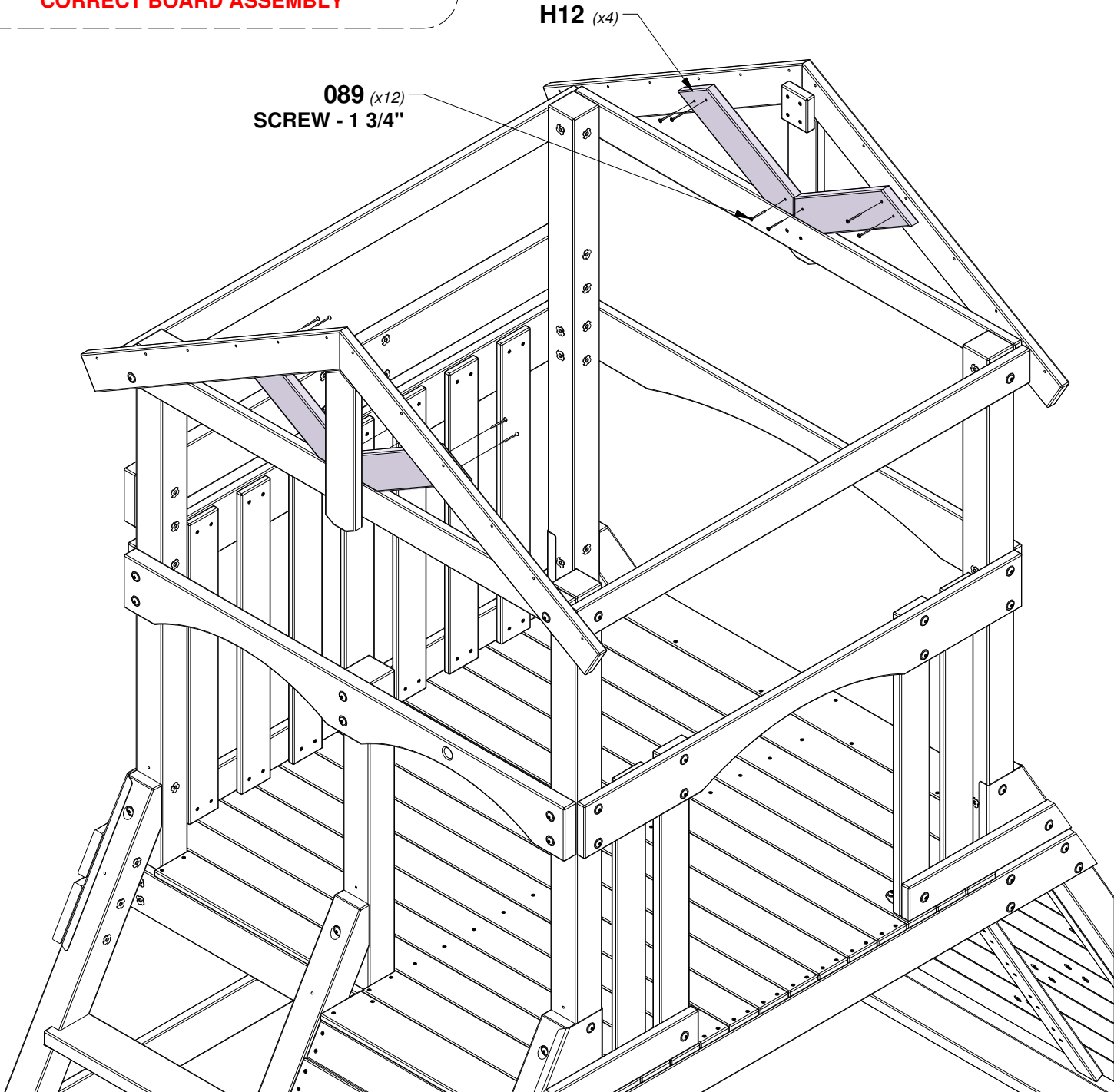
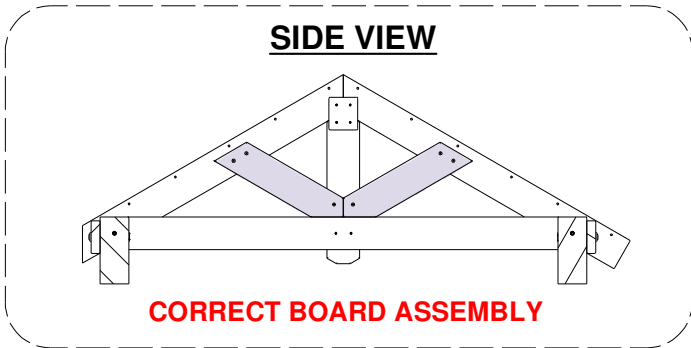



# STEP 31 - FORT ASSEMBLY

QTY	PART NUMBER	DESCRIPTION
12	H100091	SCREW PFH 8x2-1/4"



**RP1** | ROOF PANEL - W2A03410  
(x2) | 1 5/8"x15"x59 1/8" (42x382x1503)

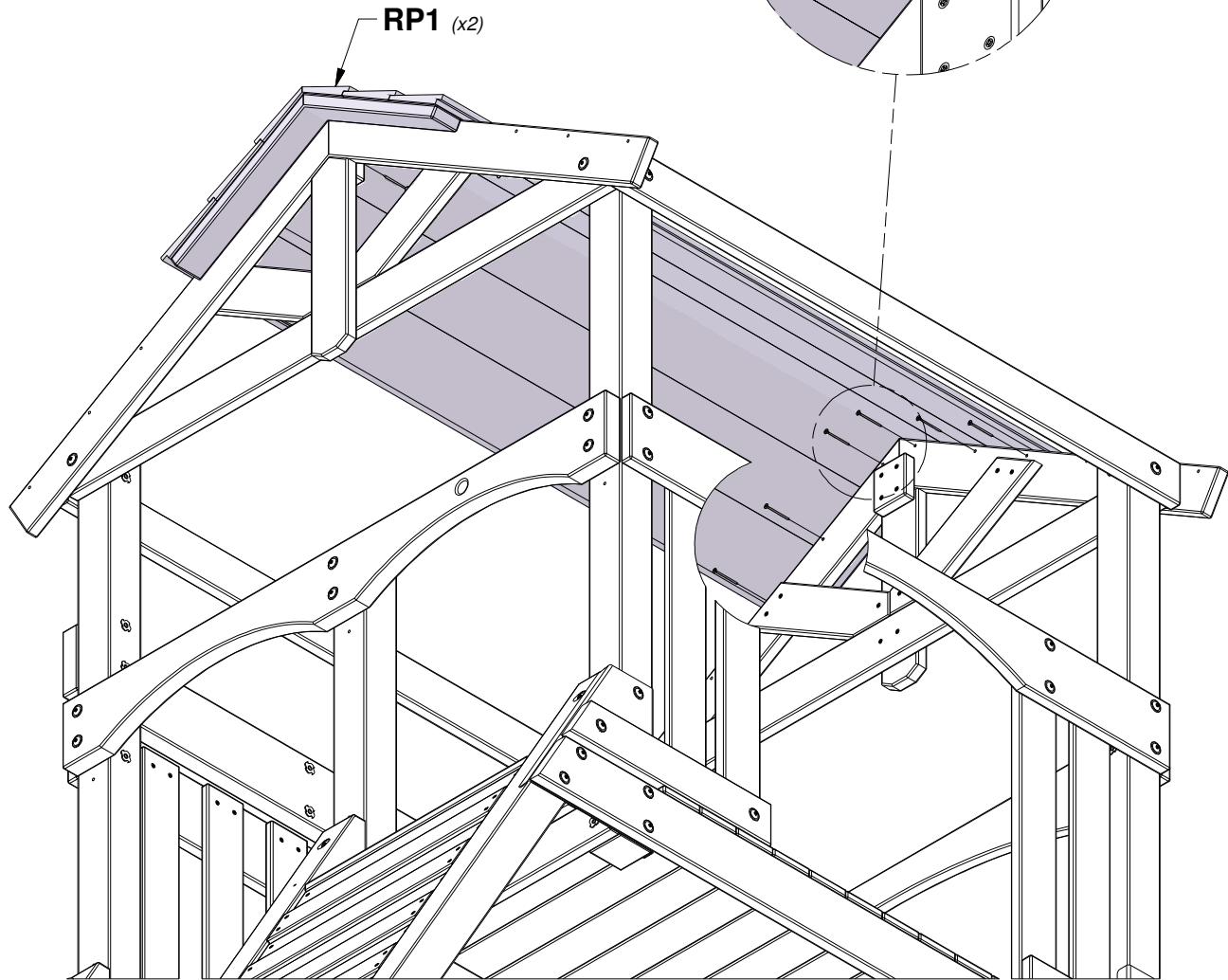
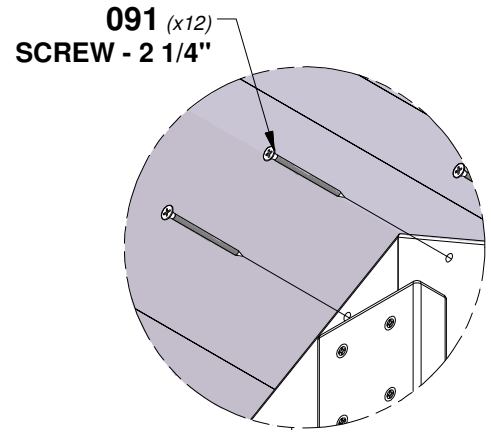
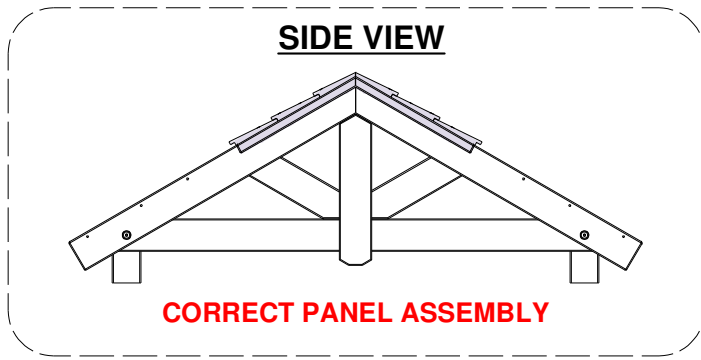

# STEP 32 - FORT ASSEMBLY

QTY	PART NUMBER	DESCRIPTION
12	H100091	SCREW PFH 8x2-1/4"



**RP2** | ROOF PANEL - W2A03411  
 (x2) | 1 5/8"x20 5/8"x66" (42x524x1503)

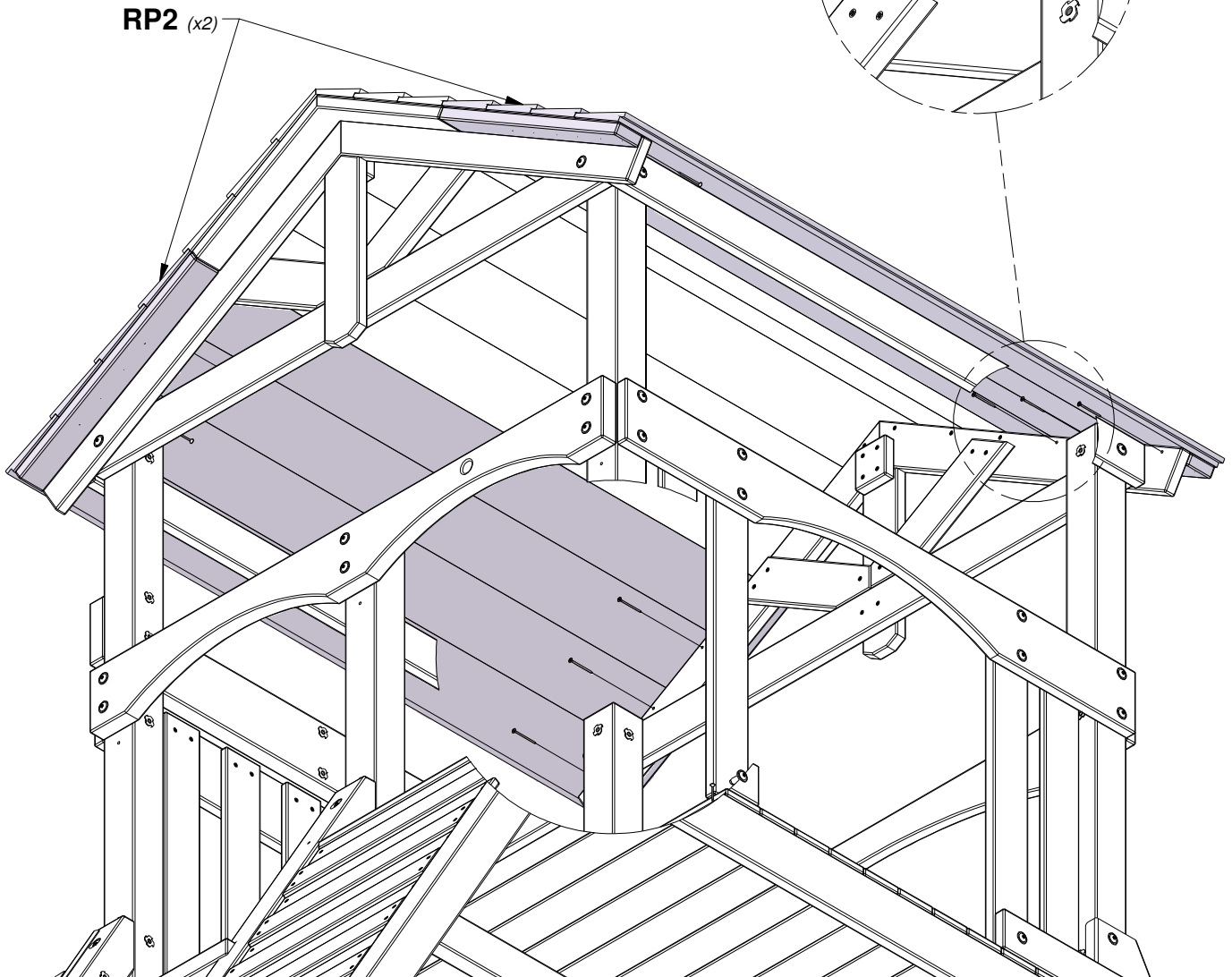
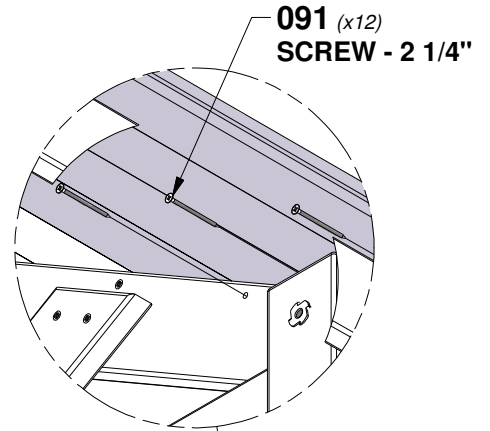
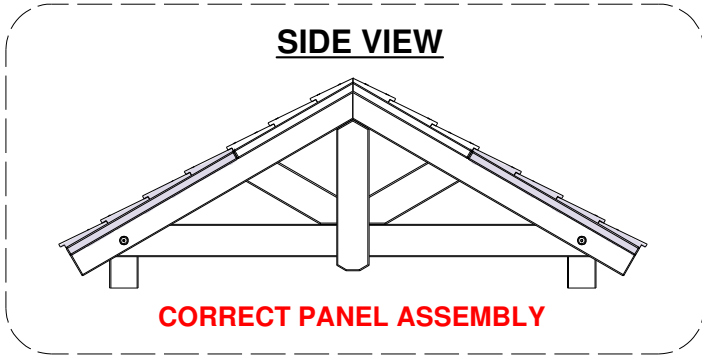

# STEP 33 - FORT ASSEMBLY

QTY	PART NUMBER	DESCRIPTION
24	H100380	SCREW PFH 8x1 1/8 BLK



**N01** | ROOF CLEAT - W4L16460  
 (x4) | 5/8"x2 3/8"x26 5/8" (16x60x675)

## BOTTOM VIEW

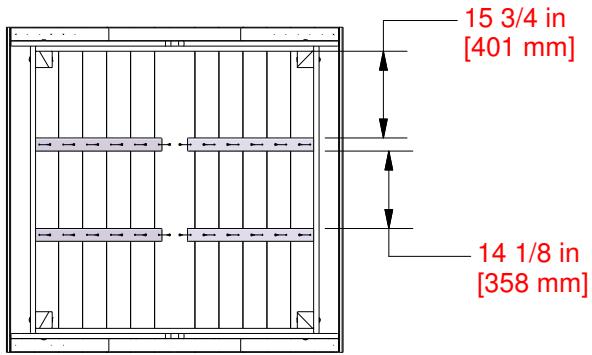

**CORRECT BOARD ASSEMBLY**

## FRONT VIEW

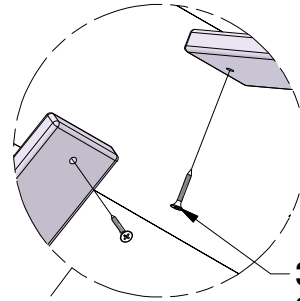
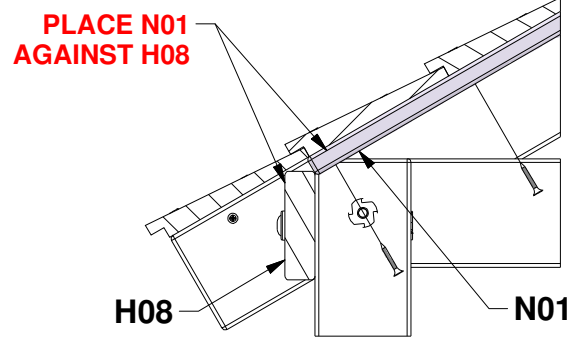

**380 (x24)**  
**SCREW - 1 1/8"**

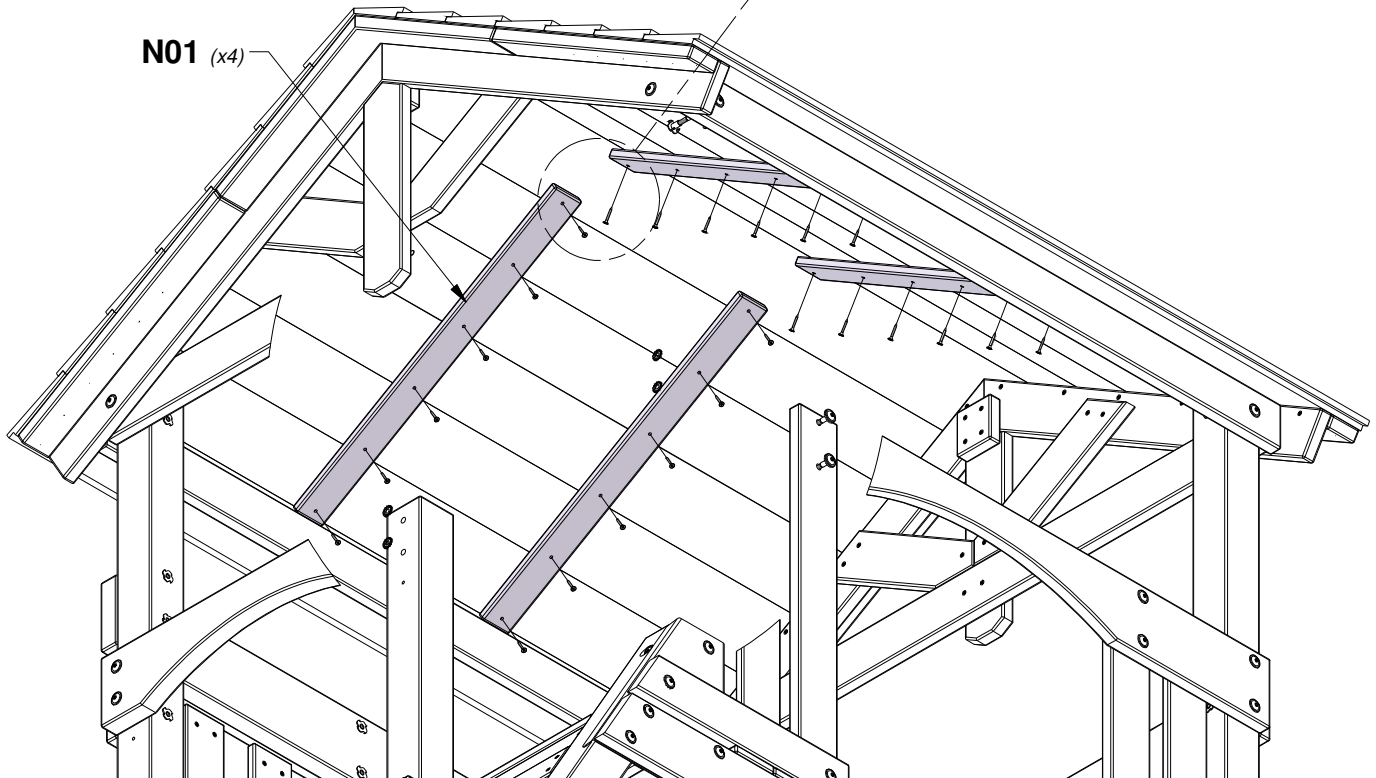

# STEP 34 - FORT ASSEMBLY

QTY	PART NUMBER	DESCRIPTION
4	H100027	LAG SCREW WH 5/16x2



**A100118** | **HAND GRIP**  
*(x2)* | **METAL GREEN**  
381 c/c

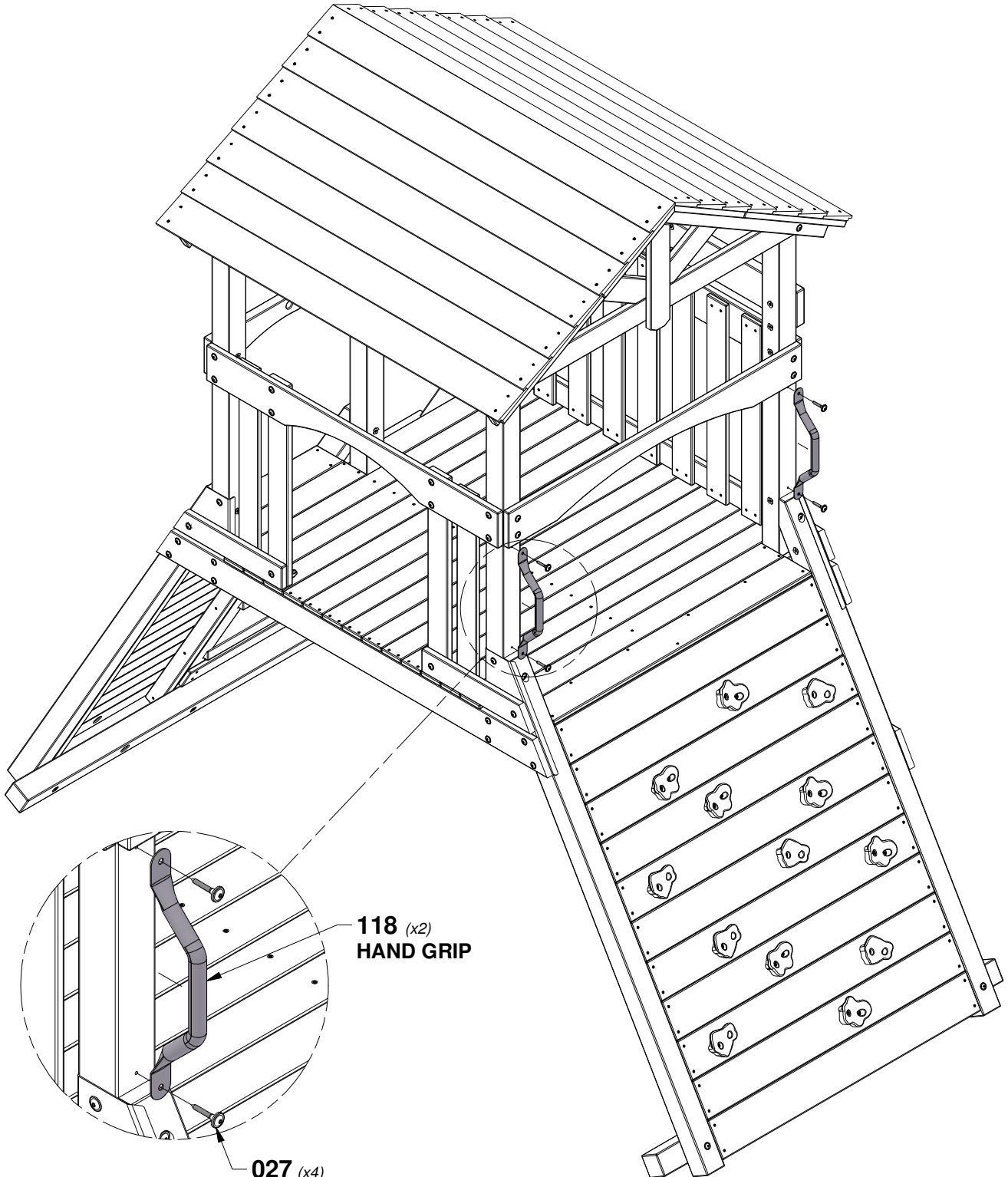

**118** *(x2)*  
**HAND GRIP**

**027** *(x4)*  
**LAG SCREW - 2"**

# STEP 35 - FORT ASSEMBLY

QTY	PART NUMBER	DESCRIPTION
6	H100027	LAG SCREW WH 5/16x2



**A100118** | **HAND GRIP**  
*(x3)* | **METAL GREEN**  
**381 c/c**

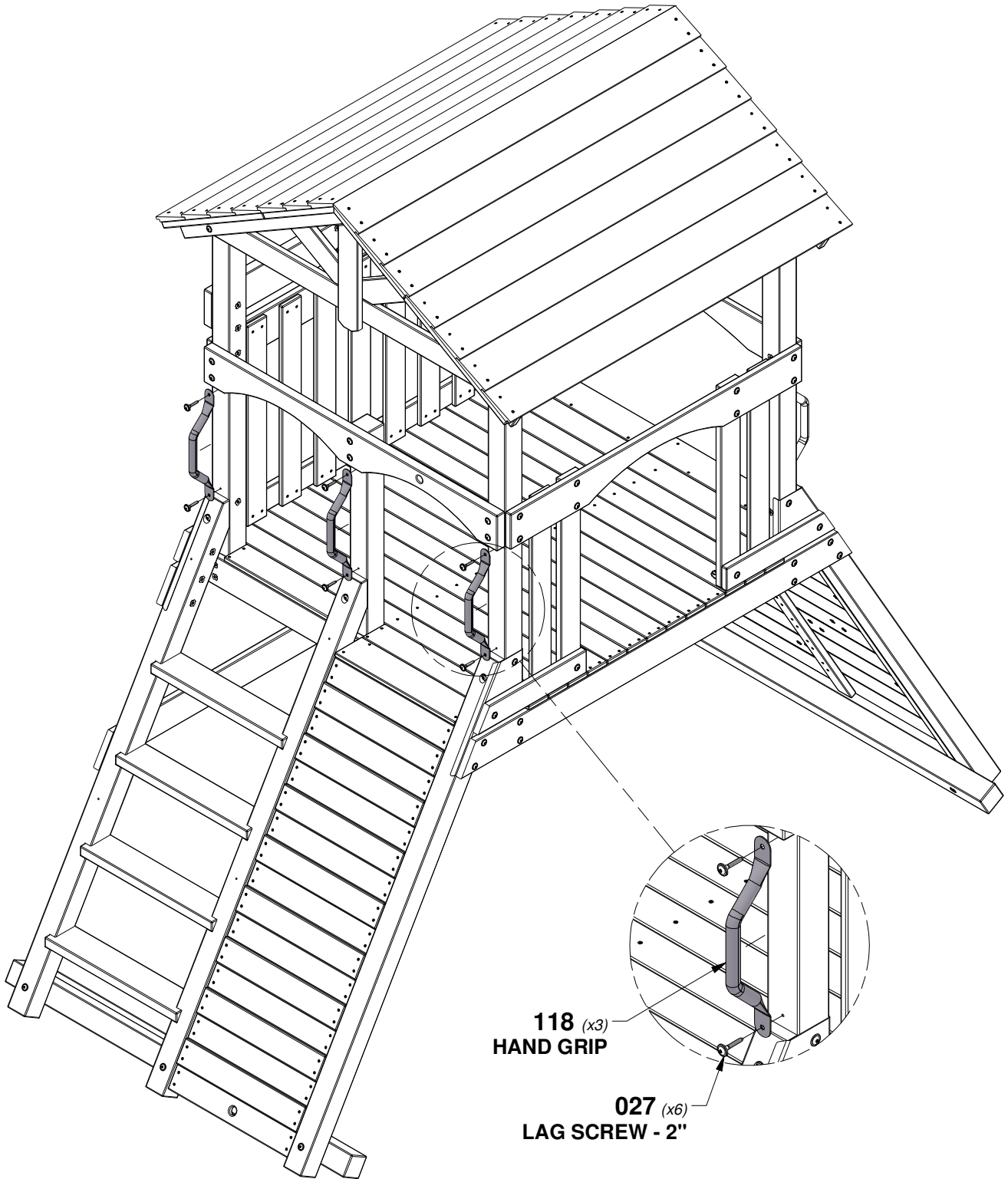

**118** *(x3)*  
**HAND GRIP**

**027** *(x6)*  
**LAG SCREW - 2"**

# STEP 36 - FORT ASSEMBLY

QTY	PART NUMBER	DESCRIPTION
4	H100027	LAG SCREW WH 5/16x2

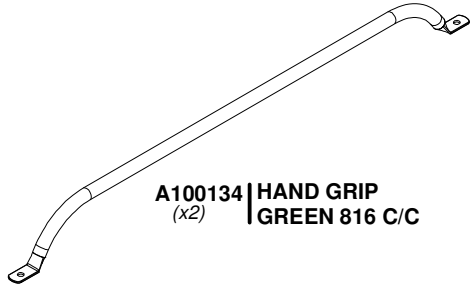

**A100134** | **HAND GRIP**  
*(x2)* | **GREEN 816 C/C**

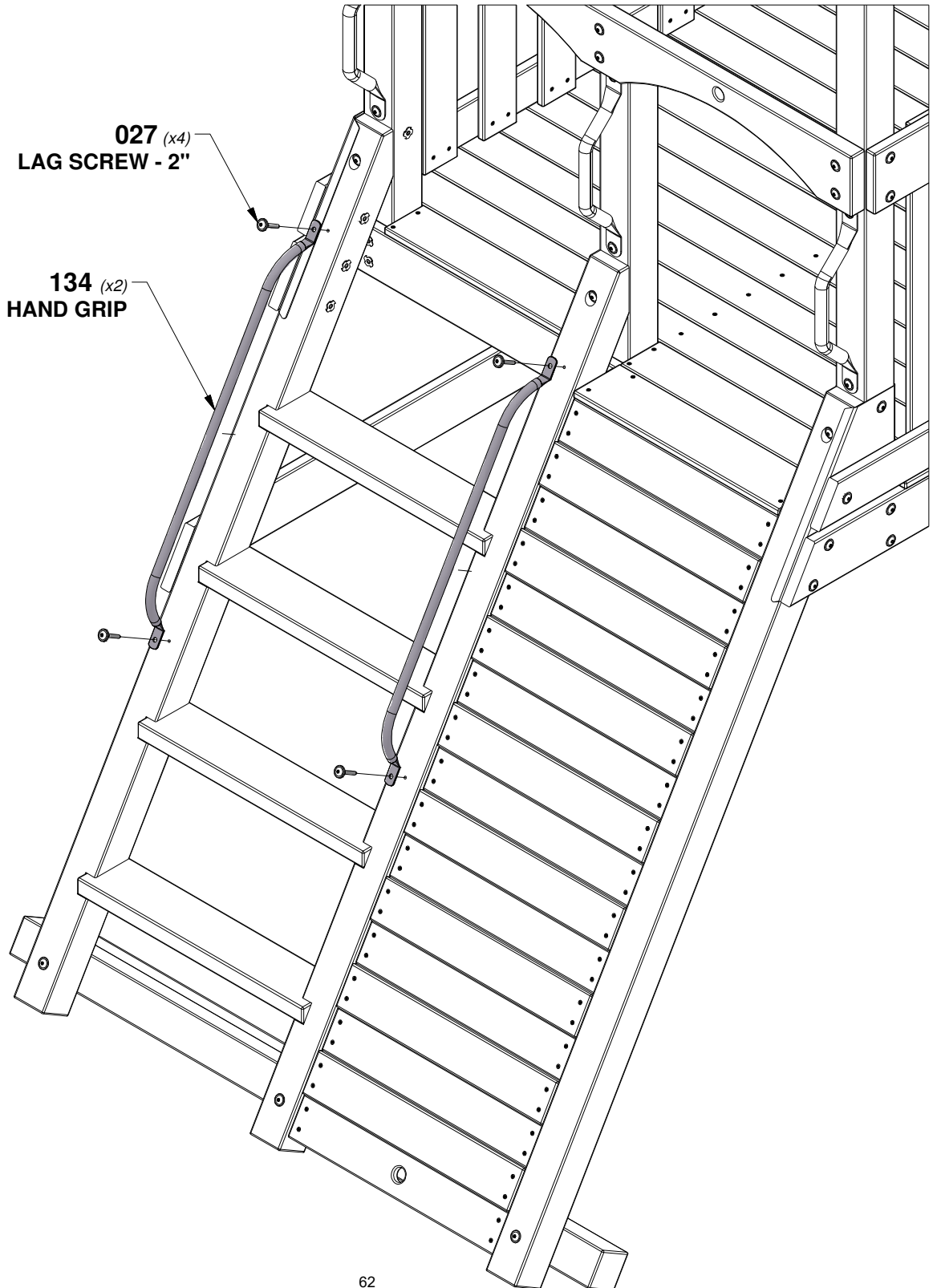

**027** *(x4)*  
**LAG SCREW - 2"**

**134** *(x2)*  
**HAND GRIP**

# STEP 38 - FORT ASSEMBLY

QTY	PART NUMBER	DESCRIPTION
4	H100477	WASHER SPLIT 5/16 BLK
4	H100478	WASHER FLAT 8x27 BLK
4	H100498	BOLT HEX 5/16x1-1/2 - BLK

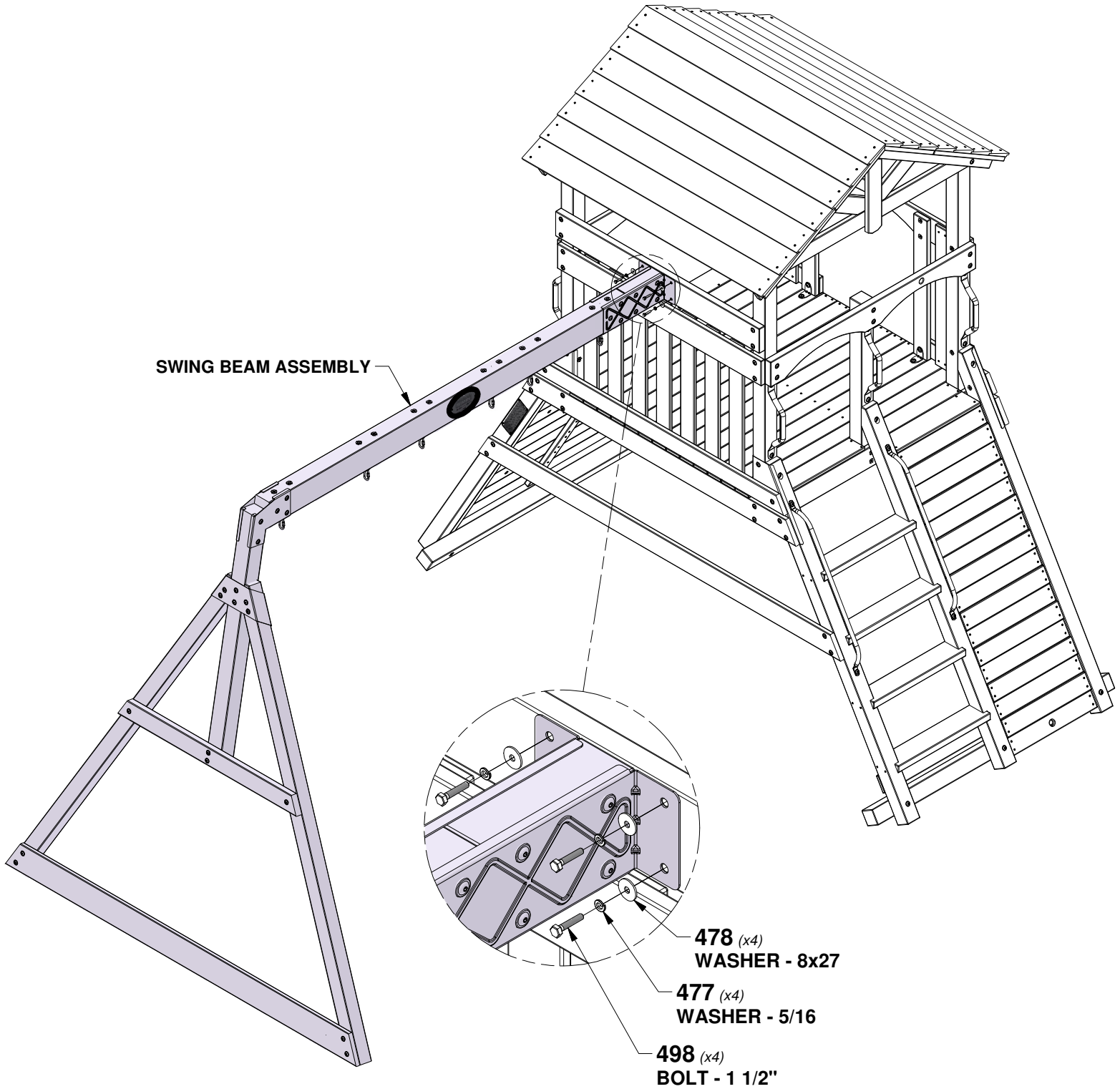
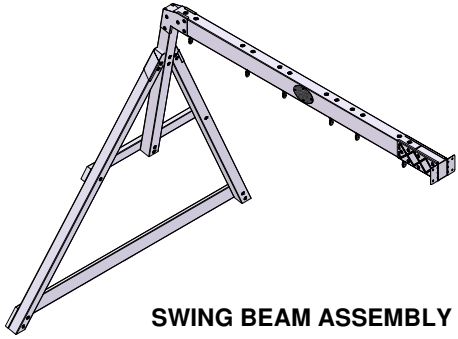

# STEP 1 - WEB SWING ASSEMBLY

QTY	PART NUMBER	DESCRIPTION
4	H100831	NUT BARREL PTH BLK 1/4x3/4
4	H100832	BOLT PTH 1/4x3/4

**IMPORTANT: SLIDE ROPE LOOPS OVER TUBE ENDS FIRST!**

SLIDE NARROW END OF TUBES INTO LARGER OPENING AFTER SLIDING ROPE LOOPS ONTO TUBES.

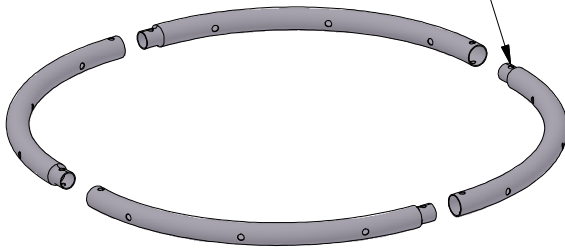

NOTE: ROPE WEBBING NOT SHOWN IN ILLUSTRATION FOR CLARITY.

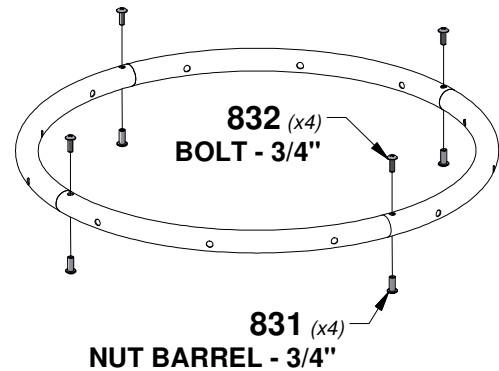

NOTE: IT IS IMPORTANT THAT THE WEB SWING HANG LEVEL.

TO ENSURE STRAIGHT SWINGING MOTION, ADJUST BOTH "S" BRACKETS UNTIL WEB SEAT IS LEVEL.

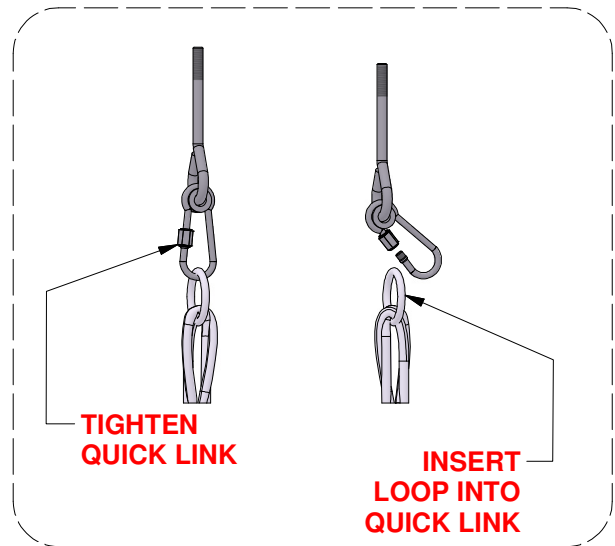

SWING MUST BE SET AT A MINIMUM OF 8 INCHES OFF THE GROUND WHEN INSTALLED.

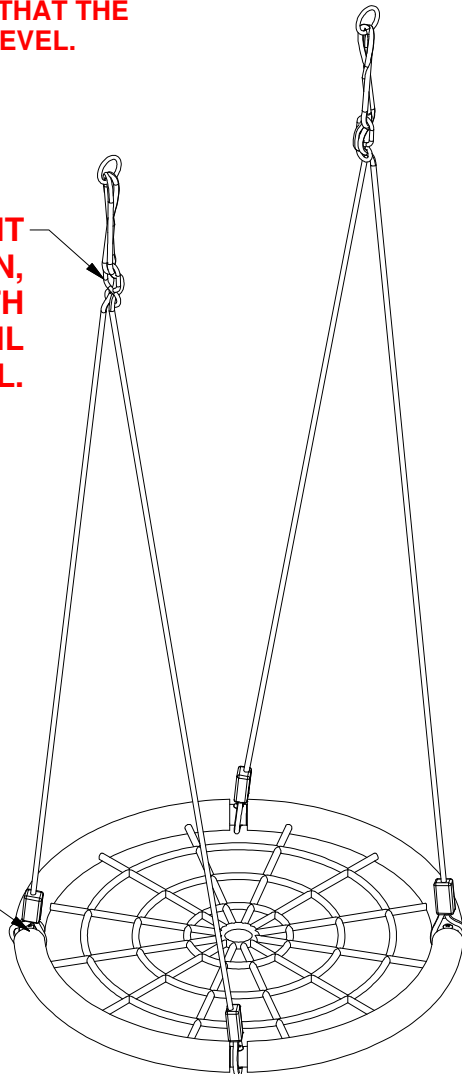



# STEP 39 - FORT ASSEMBLY



**A100027 | SWING SEAT  
(x2) | GREEN 26"**



**A100069 | QUICK LINK  
(x4)**

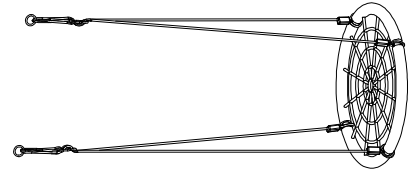

**A4M01126 | 26" WEB SWING  
(x1) | SEAT ROPE**



**A100047 | CHAIN GREEN  
(x4) | 57"**

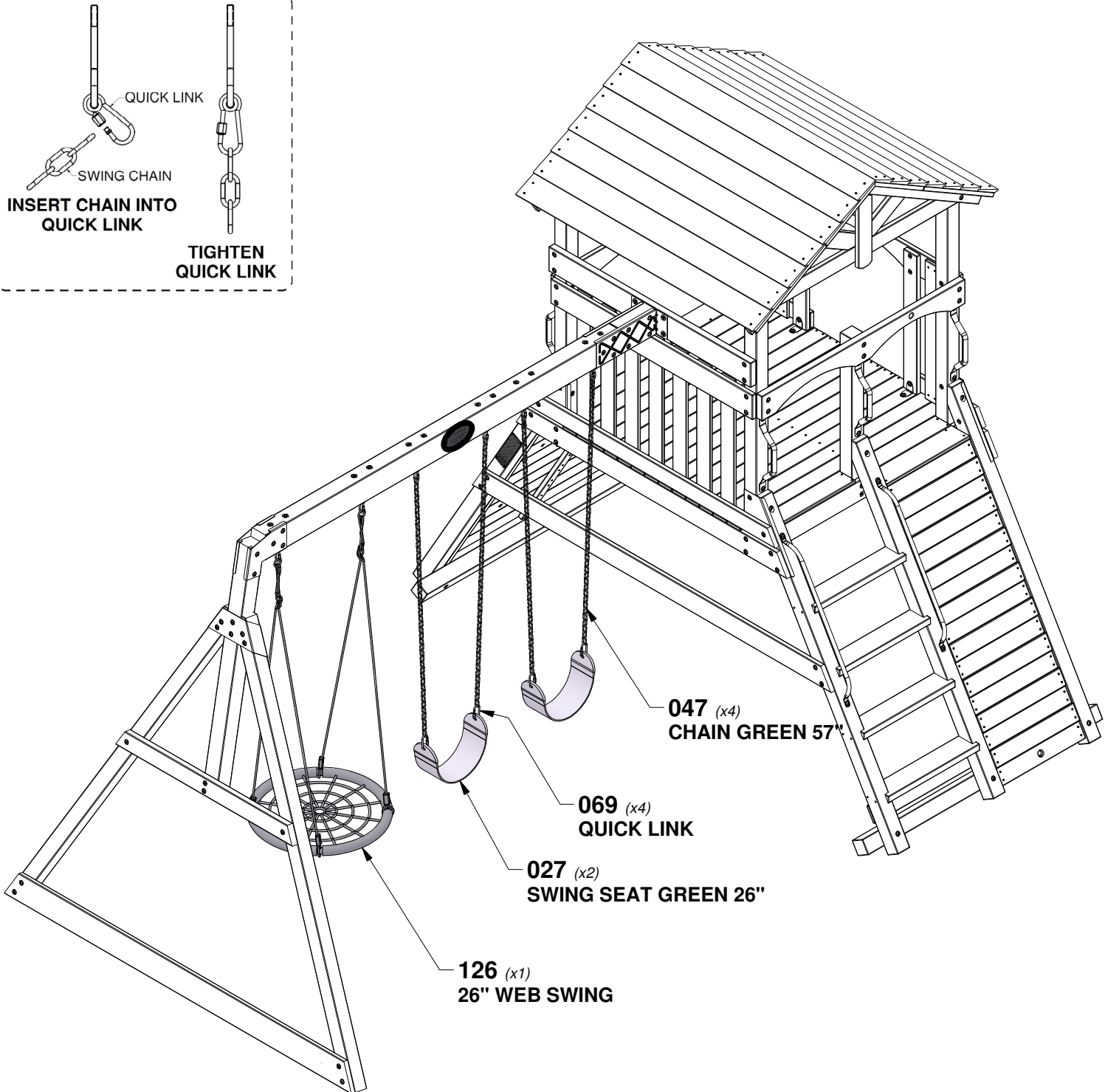
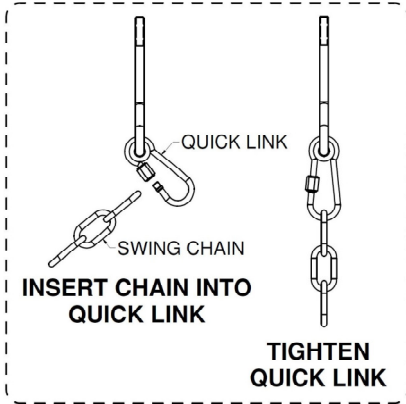

# STEP 1 - ROPE CLAMP ASSEMBLY

ROPE CLAMP ATTACHED IN NEXT STEP.

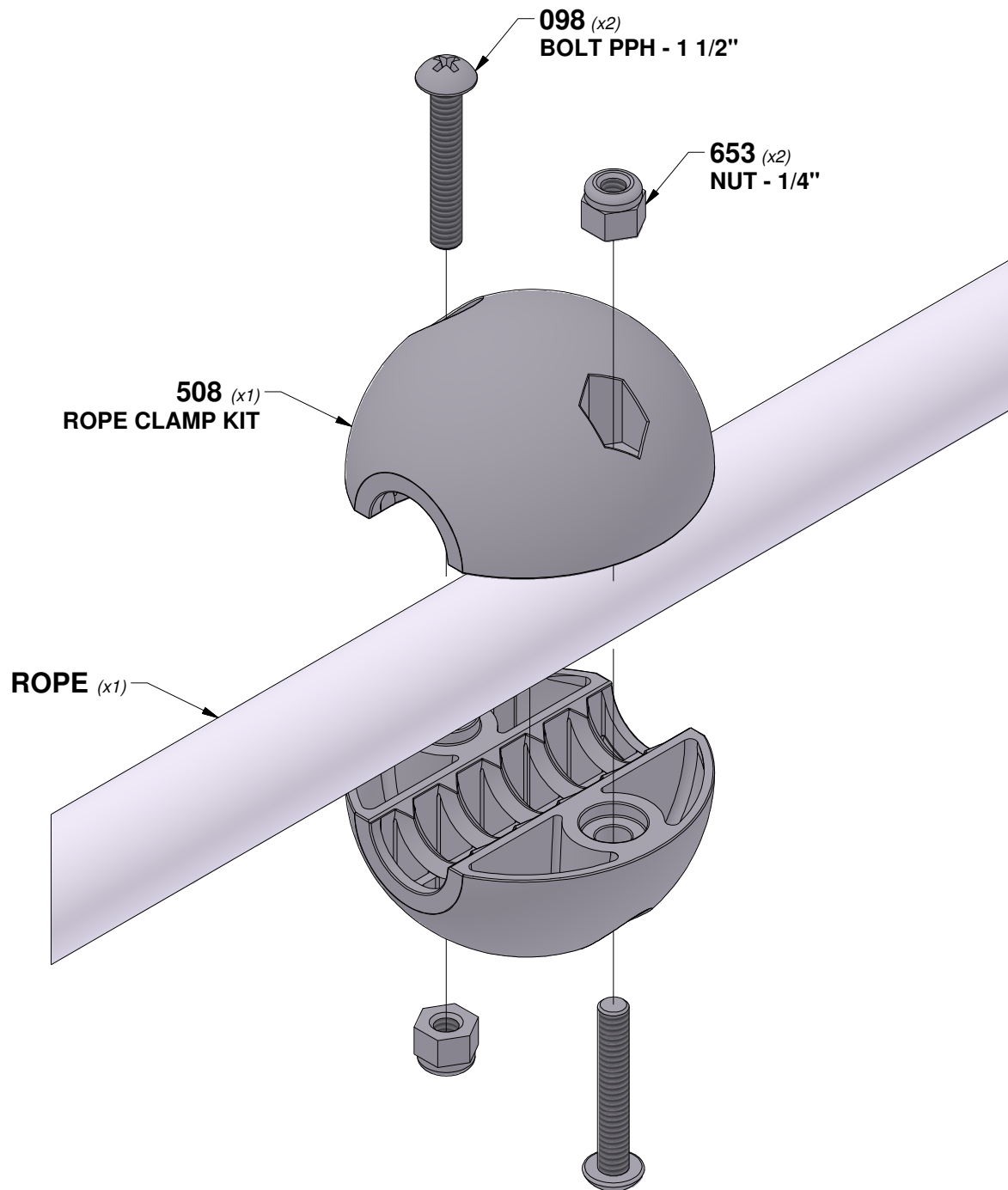

# STEP 40 - FORT ASSEMBLY

A6P00508 (x7) ROPE CLAMP KIT

A6P00520 (x1) ROPE

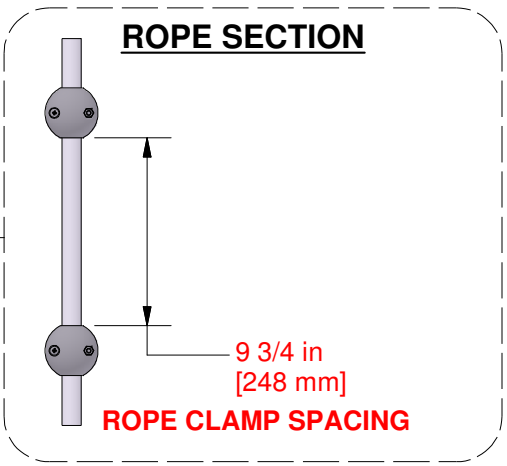
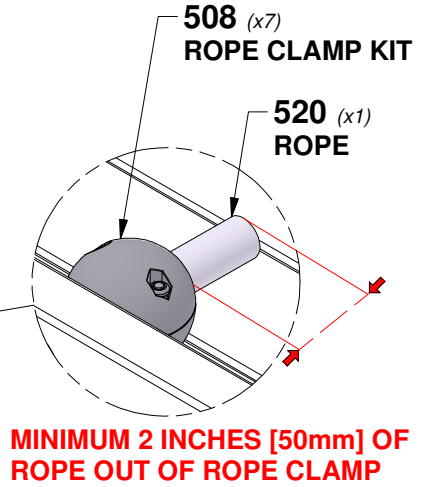
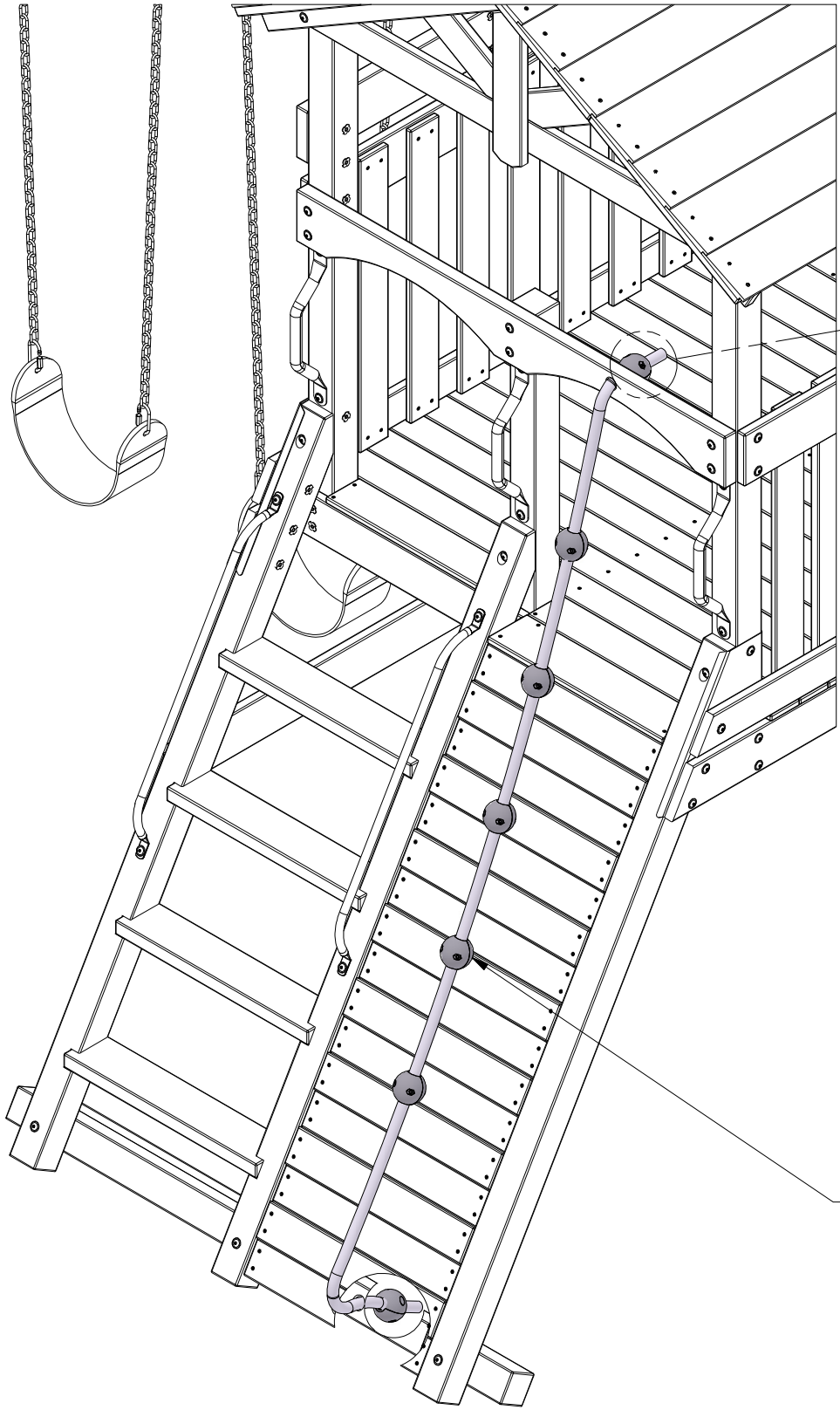

# STEP 41 - FORT ASSEMBLY

QTY	PART NUMBER	DESCRIPTION
2	H100086	SCREW PFH 8x1-1/2"

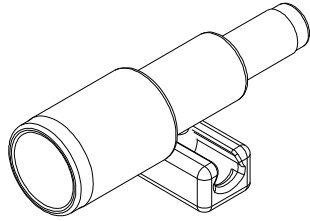

**A6P00096** | TELESCOPE  
(x1)

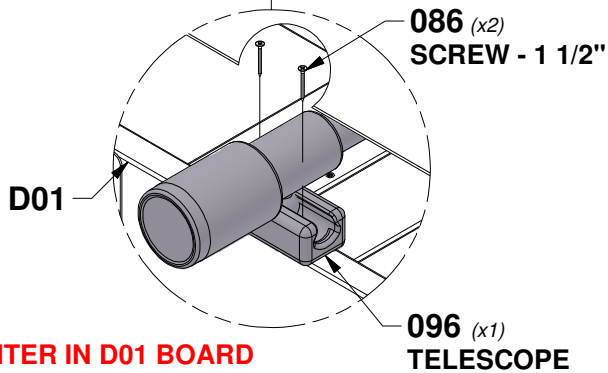
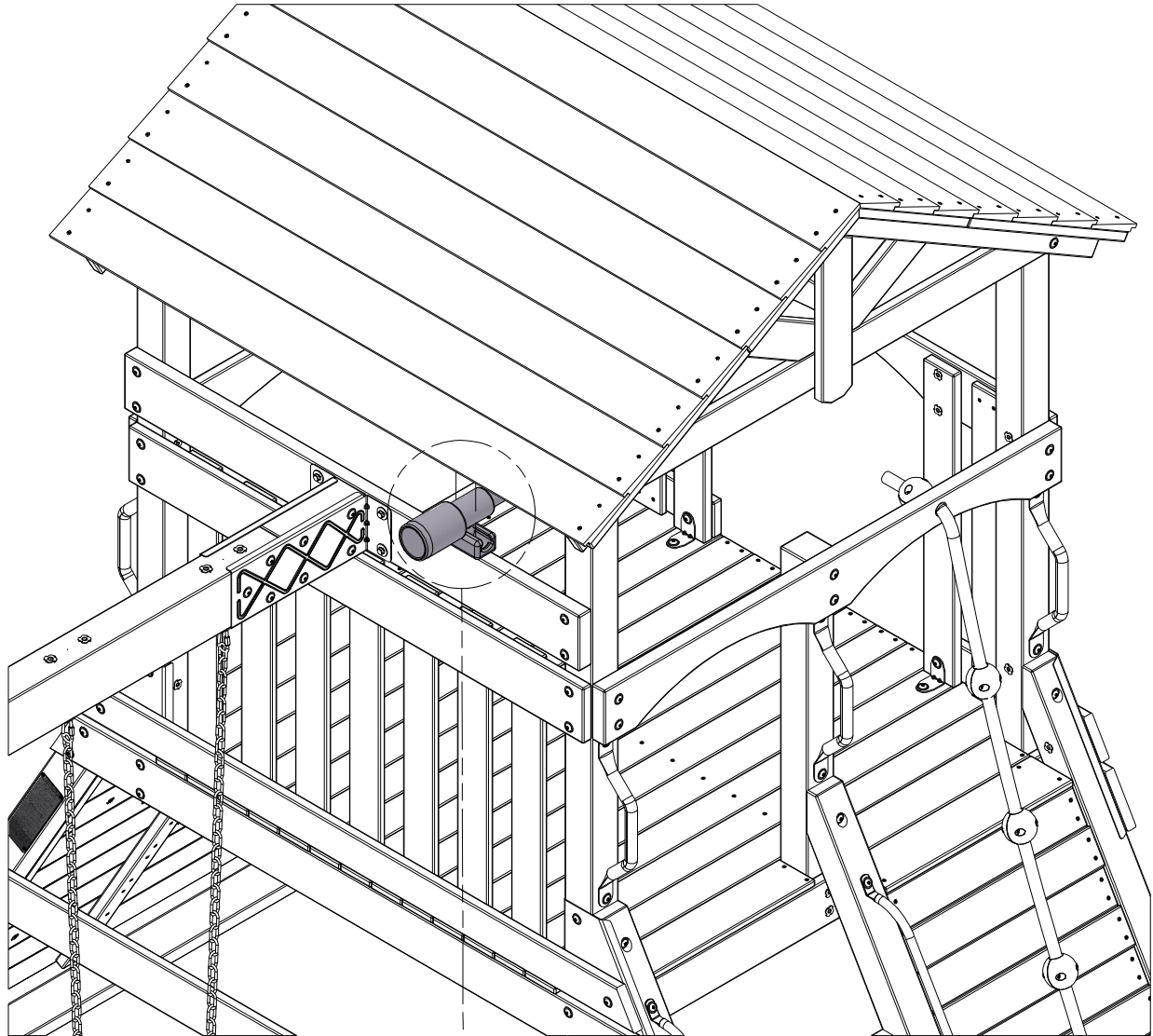

# STEP 42 - FORT ASSEMBLY

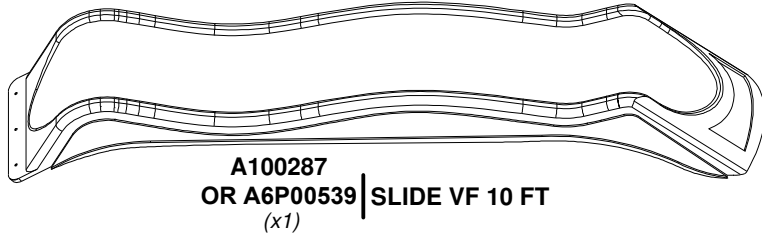

QTY	PART NUMBER	DESCRIPTION
3	H100009	BOLT WH 5/16x1 1/4
3	H100074	T-NUT 5/16"
4	H100088	SCREW PFH 8x1 1/8

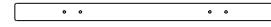

**O70** | SLIDE MOUNTING BOARD - W4L09040  
(x1) | 5/8"x1 3/8"x20 3/8" (16x34x517)

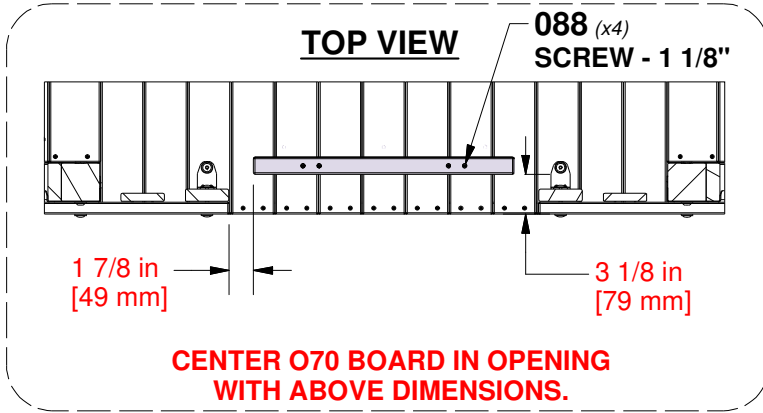

**CENTER SLIDE IN OPENING OVER O70 BOARD. USING SLIDE & O70 AS A GUIDE, DRILL (3) 3/8" [10 mm] HOLES THRU FLOOR FOR HARDWARE.**

**287 OR 539 (x1)  
SLIDE VF 10 FT**

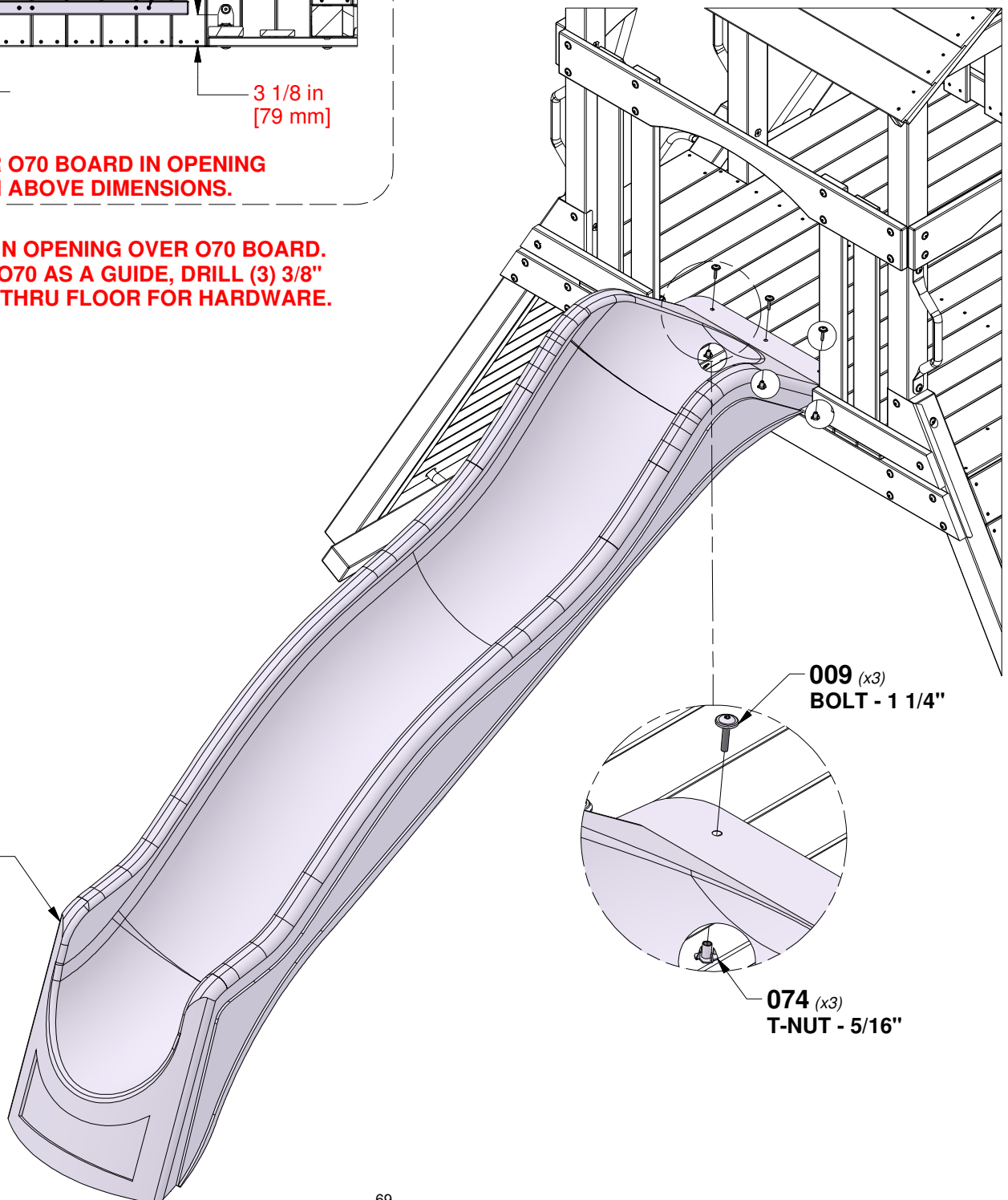

# STEP 43 - FORT ASSEMBLY

QTY	PART NUMBER	DESCRIPTION
2	H100004	NUT BARREL WH 5/16x5/8
2	H100008	BOLT WH 5/16x1
4	H100028	LAG SCREW WH 5/16x2 1/2
2	H100031	WASHER LOCK EXT 12x19



## DETAIL - A

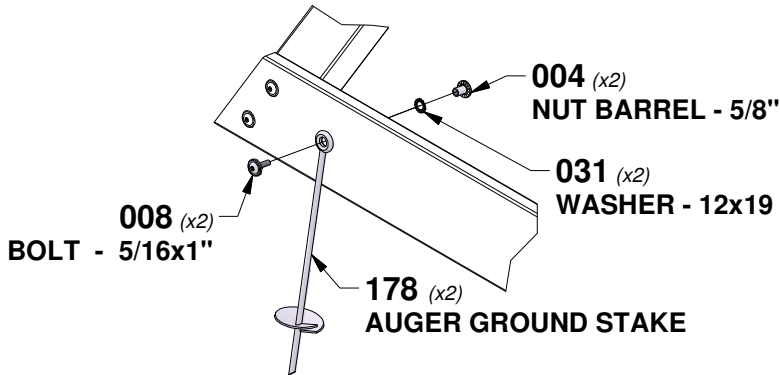

**TWIST GROUND STAKE INTO GROUND AT LOCATIONS SHOWN. USING GROUND STAKE AS A GUIDE, DRILL A 7/16" [10mm] HOLE FOR HARDWARE.**

## DETAIL - A

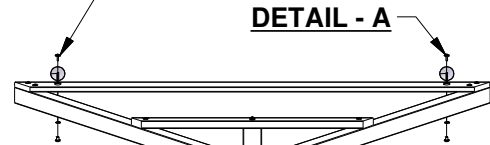

## DETAIL - B

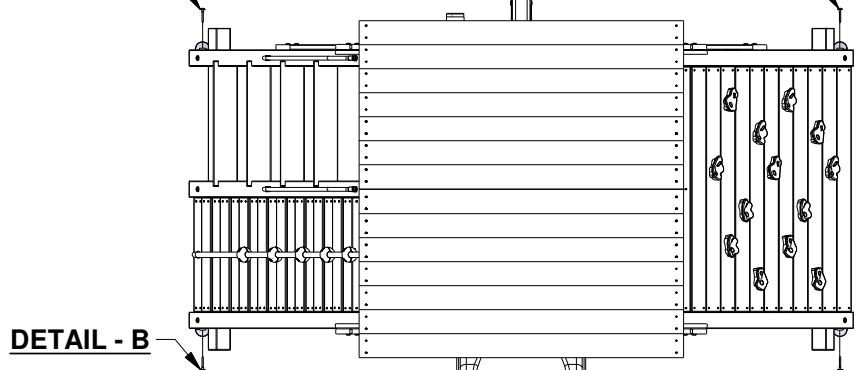

## DETAIL - B

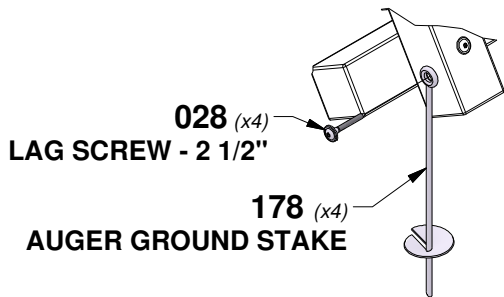

**TWIST GROUND STAKE INTO GROUND AT LOCATIONS SHOWN. USING GROUND STAKE AS A GUIDE, DRILL A 3/16" [5mm] PILOT HOLE FOR LAG BOLT.**